

CONTROL MODULE PIN-OUT INFORMATION

General Electronic Module

Pin	Description and Characteristic
O	CA86-03 INTERIOR LAMPS : TO ACTIVATE, GEM SWITCHES CIRCUIT TO GROUND
PG	CA86-05 POWER GROUND
I	CA86-14 RESET SWITCH: OPEN CIRCUIT / GROUND
I	CA86-15 TAIL GLASS RELEASE SWITCH: GROUND WHEN ACTIVATED
I	CA86-16 SET SWITCH: OPEN CIRCUIT / GROUND
I	CA87-15 LH REAR DOOR AJAR: DOOR OPEN = OPEN CIRCUIT; DOOR CLOSED = GROUND
I	IP5-03 SEDAN (EXCEPT JAPAN AND S. KOREA): EXTERNAL ANTENNA
S	IP5-18 SCP -
S	IP5-19 SCP +
SG	IP6-01 LOGIC GROUND: GROUND
I	IP6-21 PASSENGER DOOR AJAR: DOOR OPEN = OPEN CIRCUIT; DOOR CLOSED = GROUND
I	IP6-22 DRIVER DOOR AJAR: DOOR OPEN = OPEN CIRCUIT; DOOR CLOSED = GROUND
B+	JB172-05 BATTERY POWER SUPPLY (TURN SIGNALS): B+

NOTE: Refer to the Appendix at the rear of this book for Network Messages.

Fig. 09.1

COMPONENTS

Component	Connector(s)	Connector Description	Location
DOOR LATCH – DRIVER	DD3 DD9	8-WAY / BLACK 2-WAY / BLACK	DRIVER DOOR
DOOR LATCH – LH REAR	BL3 BL6	8-WAY / BLACK 2-WAY / BLACK	LH REAR DOOR
DOOR LATCH – PASSENGER	PD3 PD9	8-WAY / BLACK 2-WAY / BLACK	PASSENGER DOOR
DOOR LATCH – RH REAR	BR3 BR6	8-WAY / BLACK 2-WAY / BLACK	RH REAR DOOR
FOOTWELL LAMP – LH	IP27	2-WAY / GREY	INSTRUMENT PANEL / LH SIDE
FOOTWELL LAMP – RH	IP26	2-WAY / GREY	INSTRUMENT PANEL / RH SIDE
GENERAL ELECTRONIC MODULE	CA86 CA87 IP5 IP6 JB172	23-WAY / GREY 23-WAY / GREEN 23-WAY / BROWN 23-WAY / NATURAL 23-WAY / BLUE	BEHIND INSTRUMENT PANEL / RH SIDE
GLOVE BOX LAMP	IP25	2-WAY / BROWN	GLOVE BOX
INTERIOR LAMP – REAR	RC11 RC20	2-WAY / BLACK 1-WAY / ORANGE	REAR HEAD LINER
RF MODULE	RC35	3-WAY / BLACK	ROOF CONSOLE
ROOF CONSOLE – PRINTED CIRCUIT BOARD	RC23	20-WAY / WHITE	ROOF CENTER FRONT
ROOF CONSOLE – WITHOUT PRINTED CIRCUIT BOARD	RC30 RC31 RC33 RC34	4-WAY / BLACK 2-WAY / BLACK 4-WAY / BLACK 6-WAY / BLACK	ROOF CENTER FRONT
TAIL GATE LATCH	WT6	6-WAY / BLACK	TAIL GATE
TAIL GLASS LATCH	WT7	4-WAY / BLACK	TAIL GATE
TRUNK LAMP – LH: ESTATE (WAGON)	CA434	2-WAY / BLACK	LH REAR INTERIOR TRIM
TRUNK LAMP – RH: ESTATE (WAGON)	CA433	2-WAY / BLACK	RH REAR INTERIOR TRIM
TRUNK LAMP – SEDAN	CA132	2-WAY / BLACK	TRUNK / RH SIDE
TRUNK LOCK MOTOR	TM6	5-WAY / NATURAL	TRUNK LID
VANITY MIRROR LAMP – LH	RC9	2-WAY / BLACK	LH SUN VISOR
VANITY MIRROR LAMP – RH	RC8	2-WAY / BLACK	RH SUN VISOR

HARNESS IN-LINE CONNECTORS

Connector	Connector Description	Location
CA1	22-WAY / NATURAL / INSTRUMENT PANEL HARNESS TO CABIN HARNESS	LH 'A' POST / 'A' POST TRIM
CA15	20-WAY / BLACK / CABIN HARNESS TO DRIVER DOOR HARNESS	DRIVER DOOR / DOOR CASING
CA16	20-WAY / BLACK / CABIN HARNESS TO DRIVER DOOR HARNESS	DRIVER DOOR / DOOR CASING
CA20	20-WAY / BLACK / CABIN HARNESS TO PASSENGER DOOR HARNESS	PASSENGER DOOR / DOOR CASING
CA25	14-WAY / NATURAL / CABIN HARNESS TO LH REAR DOOR HARNESS	LH 'B/C' POST / 'B/C' POST TRIM
CA30	14-WAY / NATURAL / CABIN HARNESS TO RH REAR DOOR HARNESS	RH 'B/C' POST / 'B/C' POST TRIM
CA36	16-WAY / GREEN / CABIN HARNESS TO ROOF HARNESS	LH 'A' POST / WINDSHIELD PILLAR
CA40	16-WAY / GREY / CABIN HARNESS TO ROOF HARNESS	RH 'A' POST / WINDSHIELD PILLAR
CA45	6-WAY / GREY / CABIN HARNESS TO TRUNK LID HARNESS	BEHIND LH 'E' POST TRIM
CA240	12-WAY / GREY / CABIN HARNESS TO INSTRUMENT PANEL HARNESS	LH LOWER 'A' POST / 'A' POST TRIM
TL10	6-WAY / GREY / TRUNK LINK LEAD TO TRUNK LID HARNESS	BELOW PARCEL SHELF / LH SIDE
WL1	8-WAY / BLACK / CABIN HARNESS TO TAIL GATE LINK LEAD	ROOF / CENTER REAR
WL3	3-WAY / BLACK / CABIN HARNESS TO TAIL GATE LINK LEAD	ROOF / CENTER REAR
WT1	8-WAY / BLACK / CABIN HARNESS TO TAIL GATE HARNESS	TAIL GATE
WT3	3-WAY / BLACK / CABIN HARNESS TO TAIL GATE HARNESS	TAIL GATE

GROUNDINGS

Ground	Harness	Location
G1	CA	TRUNK / UNDER LH TAIL LAMP UNIT
G2	CA	TRUNK / UNDER LH TAIL LAMP UNIT
G4	CA	LOWER RH 'A' POST
G5	IP	UPPER RH 'A' POST
G15	CA	LOWER LH 'A' POST
G37	IP	BEHIND INSTRUMENT PANEL / RH SIDE OF CROSS CAR BEAM

FOR CONTROL MODULE PIN-OUT INFORMATION, UNFOLD PAGE TO LEFT.

The following abbreviations are used to represent values for Control Module Pin-Out data

I	Input	PG	Power Ground	C	CAN Network	D	Serial and Encoded Data
O	Output	SS	Sensor / Signal Supply V	S	SCP Network	V	Voltage (DC)
B+	Battery Voltage	SG	Sensor / Signal Ground	D2	D2B Network	PWM	Pulse Width Modulated

CAUTION: The information on this data page is furnished to aid the user in understanding circuit operation. THIS INFORMATION SHOULD BE USED FOR REFERENCE ONLY.

NOTE: The values listed are approximately those that can be expected at the control module connector pins with all circuit connections made and all components connected and fitted.

Refer to the front of this book for detailed information and illustrations regarding the location and identification of harnesses, relays, fuses, grounds, control modules and control module pins.

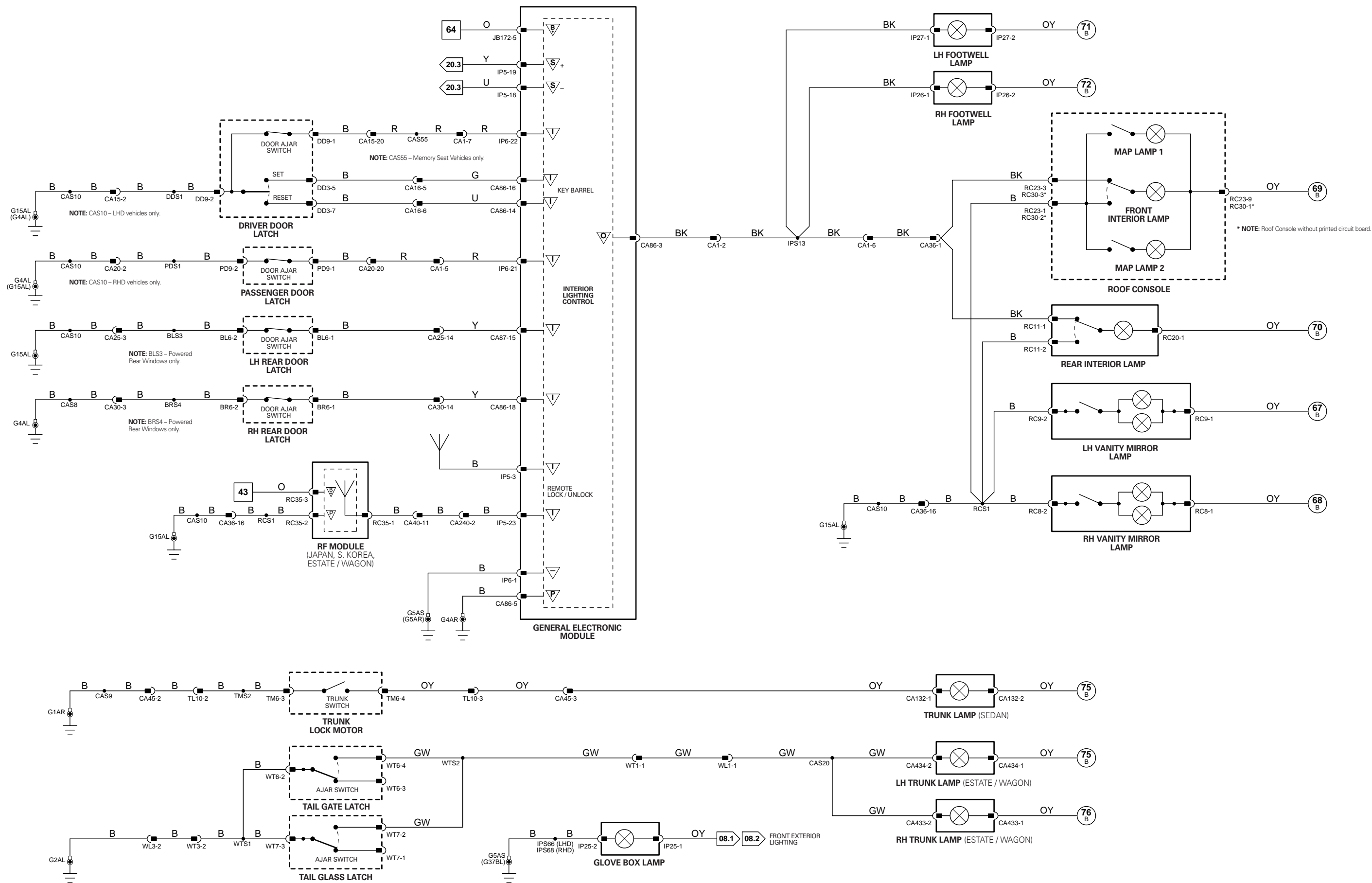

Fig. 09.2

COMPONENTS

Component	Connector(s)	Connector Description	Location
AUDIO UNIT	ID1 IP65 IP106	2-WAY / D2B 20-WAY / BLACK 2-WAY / METALLIC	INSTRUMENT PANEL CENTER
CIGAR LIGHTER	IP42	2-WAY / ORANGE	ASH TRAY
CLIMATE CONTROL MODULE – PANEL	AC1 IP39 IP101 IP135	26-WAY / YELLOW 4-WAY / GREY 26-WAY / WHITE 2-WAY / GREY	BEHIND CLIMATE CONTROL PANEL
DOOR SWITCH PACK – DRIVER	DD1	20-WAY / BLACK	DRIVER DOOR CASING
DOOR SWITCH PACK – LH REAR	BL1	8-WAY / BLACK	LH REAR DOOR CASING
DOOR SWITCH PACK – PASSENGER	PD10	8-WAY / BLACK	PASSENGER DOOR CASING
DOOR SWITCH PACK – RH REAR	BR1	8-WAY / BLACK	RH REAR DOOR CASING
HAZARD AND SEAT HEATER SWITCHES	IP51	6-WAY / BLACK	CENTER CONSOLE
INSTRUMENT CLUSTER	IP10 IP11	26-WAY / WHITE 26-WAY / WHITE	INSTRUMENT PANEL
J-GATE MODULE	IP14	16-WAY / GREY	CENTER CONSOLE
MASTER LIGHTING SWITCH	IP17	16-WAY / BLACK	INSTRUMENT PANEL
ROOF CONSOLE – PRINTED CIRCUIT BOARD	RC23	20-WAY / WHITE	ROOF CENTER FRONT
STEERING WHEEL	SW4	6-WAY / BLACK	STEERING COLUMN
TELEMATICS DISPLAY	IP70 IP136 IP137 IP138 IP139	22-WAY / BLACK 2-WAY / METALLIC 2-WAY / METALLIC 2-WAY / METALLIC 2-WAY / METALLIC	CENTER CONSOLE
TRACTION CONTROL / DYNAMIC STABILITY CONTROL SWITCH	IP29	6-WAY / BLACK	INSTRUMENT PANEL

HARNESS IN-LINE CONNECTORS

Connector	Connector Description	Location
CA1	22-WAY / NATURAL / INSTRUMENT PANEL HARNESS TO CABIN HARNESS	LH 'A' POST / 'A' POST TRIM
CA15	20-WAY / BLACK / CABIN HARNESS TO DRIVER DOOR HARNESS	DRIVER DOOR / DOOR CASING
CA20	20-WAY / BLACK / CABIN HARNESS TO PASSENGER DOOR HARNESS	PASSENGER DOOR / DOOR CASING
CA25	14-WAY / NATURAL / CABIN HARNESS TO LH REAR DOOR HARNESS	LH 'B/C' POST / 'B/C' POST TRIM
CA30	14-WAY / NATURAL / CABIN HARNESS TO RH REAR DOOR HARNESS	RH 'B/C' POST / 'B/C' POST TRIM
CA36	16-WAY / GREEN / CABIN HARNESS TO ROOF HARNESS	LH 'A' POST / WINDSHIELD PILLAR
IP34	10-WAY / NATURAL / INSTRUMENT PANEL HARNESS TO STEERING WHEEL HARNESS	STEERING WHEEL CASSETTE
JB1	42-WAY / BLACK / ENGINE MANAGEMENT HARNESS TO JUNCTION BOX HARNESS	ENGINE COMPARTMENT / LH SIDE
JB129	22-WAY / GREY / JUNCTION BOX HARNESS TO INSTRUMENT PANEL HARNESS	BELOW INSTRUMENT PANEL / LH SIDE

GROUND

Ground	Harness	Location
G14	JB	ENGINE COMPARTMENT / BEHIND POWER DISTRIBUTION FUSE BOX
G15	CA	LOWER LH 'A' POST
G35	CA	LOWER LH 'E' POST
G36	IP	BEHIND INSTRUMENT PANEL / LH SIDE OF CROSS CAR BEAM
G37	IP	BEHIND INSTRUMENT PANEL / RH SIDE OF CROSS CAR BEAM
G38	CA	UPPER LH 'E' POST
G4	CA	LOWER RH 'A' POST

Refer to the front of this book for detailed information and illustrations regarding the location and identification of harnesses, relays, fuses, grounds, control modules and control module pins.

