

Transmission Control Module – 16-BIT

Pin	Description and Characteristic
O	JB131-03 2 / 4 BRAKE PRESSURE CONTROL SOLENOID DRIVE: PWM, 1.25 kHz, POSITIVE DUTY CYCLE 5 – 95%
O	JB131-04 2 / 4 BRAKE TIMING SOLENOID DRIVE: B+ TO ACTIVATE
I	JB131-05 OUTPUT SPEED SENSOR SIGNAL: 18 PULSES PER OUTPUT SHAFT REVOLUTION
B+	JB131-06 BATTERY POWER SUPPLY: B+
I	JB131-07 GEAR SELECTOR SIGNAL – 3: 3 = GROUND; NOT IN 3 = OPEN CIRCUIT
I	JB131-08 GEAR SELECTOR SIGNAL – 2: 2 = GROUND; NOT IN 2 = OPEN CIRCUIT
PG	JB131-09 POWER GROUND: GROUND
O	JB131-10 REDUCTION TIMING SOLENOID DRIVE: B+ TO ACTIVATE
C	JB131-12 CAN – 1
C	JB131-13 CAN – 2
O	JB131-14 SHIFT SOLENOID B DRIVE: B+ TO ACTIVATE
O	JB131-15 SHIFT SOLENOID A DRIVE: B+ TO ACTIVATE
O	JB131-16 TCC PRESSURE CONTROL SOLENOID DRIVE: PWM, 1.25 kHz, POSITIVE DUTY CYCLE 5 – 95%
SG	JB131-17 SOLENOID GROUND RETURN: GROUND
O	JB131-18 LINE PRESSURE CONTROL SOLENOID DRIVE: PWM, 1.25 kHz, POSITIVE DUTY CYCLE 5 – 95%
SG	JB131-20 SENSOR GROUND: GROUND
I	JB131-21 INTERMEDIATE SPEED SENSOR SIGNAL: 54 PULSES PER INTERMEDIATE SHAFT REVOLUTION*
I	JB131-24 TURBINE SPEED SENSOR SIGNAL: 36 PULSES PER ENGINE REVOLUTION
I	JB131-25 RANGE SENSOR – N: N = GROUND; NOT IN N = OPEN CIRCUIT
I	JB131-26 RANGE SENSOR – R: R = GROUND; NOT IN R = OPEN CIRCUIT
I	JB131-27 RANGE SENSOR – D: D = GROUND; NOT IN D = OPEN CIRCUIT
I	JB131-30 RANGE SENSOR – P: P = GROUND; NOT IN P = OPEN CIRCUIT
C	JB131-33 CAN + 1
C	JB131-34 CAN + 2
B+	JB131-36 IGNITION SWITCHED POWER SUPPLY: B+
PG	JB131-38 POWER GROUND: GROUND
I	JB131-39 FLUID TEMPERATURE SENSOR SIGNAL, NOMINAL 0 – 5 V: NTC SENSOR – VOLTAGE DECREASES AS TEMPERATURE INCREASES
SG	JB131-42 OUTPUT SPEED SENSOR GROUND: GROUND
SG	JB131-44 TURBINE SPEED SENSOR GROUND: GROUND
I	JB131-45 GEAR SELECTOR SIGNAL – 4: 4 = GROUND; NOT IN 4 = OPEN CIRCUIT
SG	JB131-46 INTERMEDIATE SPEED SENSOR GROUND: GROUND
I	JB131-47 MODE SWITCH: 'SPORT' SELECTED = GROUND
O	JB131-52 SHIFT SOLENOID C DRIVE: B+ TO ACTIVATE
O	JB131-53 LOW CLUTCH TIMING SOLENOID DRIVE: B+ TO ACTIVATE
B+	JB131-54 IGNITION SWITCHED POWER SUPPLY: B+

* IN 1ST – 4TH AND R, THE INTERMEDIATE SHAFT SPEED IS THE SAME AS THE OUTPUT SHAFT SPEED. IN 5TH, THE INTERMEDIATE SHAFT SPEED IS MULTIPLIED BY 1.2.

The following abbreviations are used to represent values for Control Module Pin-Out data

I	Input	PG	Power Ground	C	CAN Network	D	Serial and Encoded Data
O	Output	SS	Sensor / Signal Supply V	S	SCP Network	V	Voltage (DC)
B+	Battery Voltage	SG	Sensor / Signal Ground	D2	D2B Network	PWM	Pulse Width Modulated

CAUTION: The information on this data page is furnished to aid the user in understanding circuit operation. THIS INFORMATION SHOULD BE USED FOR REFERENCE ONLY.

NOTE: The values listed are approximately those that can be expected at the control module connector pins with all circuit connections made and all components connected and fitted.

Fig. 04.1

COMPONENTS

Component	Connector(s)	Connector Description	Location
AUTOMATIC TRANSMISSION	JB155	18-WAY / BLACK	ENGINE COMPARTMENT
IGNITION SWITCH	IP18	7-WAY / BLACK	STEERING COLUMN
J-GATE MODULE	IP14	16-WAY / GREY	CENTER CONSOLE
TRANSMISSION CONTROL MODULE – 16-BIT	JB131	37-WAY / BLUE	LOWER LH 'A' POST
TRANSMISSION RANGE SENSOR	JB156	10-WAY / BLACK	TOP OF TRANSMISSION

HARNESS IN-LINE CONNECTORS

Connector	Connector Description / Location	Location
JB129	22-WAY / GREY / JUNCTION BOX HARNESS TO INSTRUMENT PANEL HARNESS	BELOW INSTRUMENT PANEL / LH SIDE

GROUNDS

Ground	Harness	Location
G14	JB	ENGINE COMPARTMENT / BEHIND POWER DISTRIBUTION FUSEBOX
G15	CA	LOWER LH 'A' POST
G37	IP	BEHIND INSTRUMENT PANEL / RH SIDE OF CROSS CAR BEAM

FOR CONTROL MODULE PIN-OUT INFORMATION, UNFOLD PAGE TO LEFT.

Refer to the front of this book for detailed information and illustrations regarding the location and identification of harnesses, relays, fuses, grounds, control modules and control module pins.

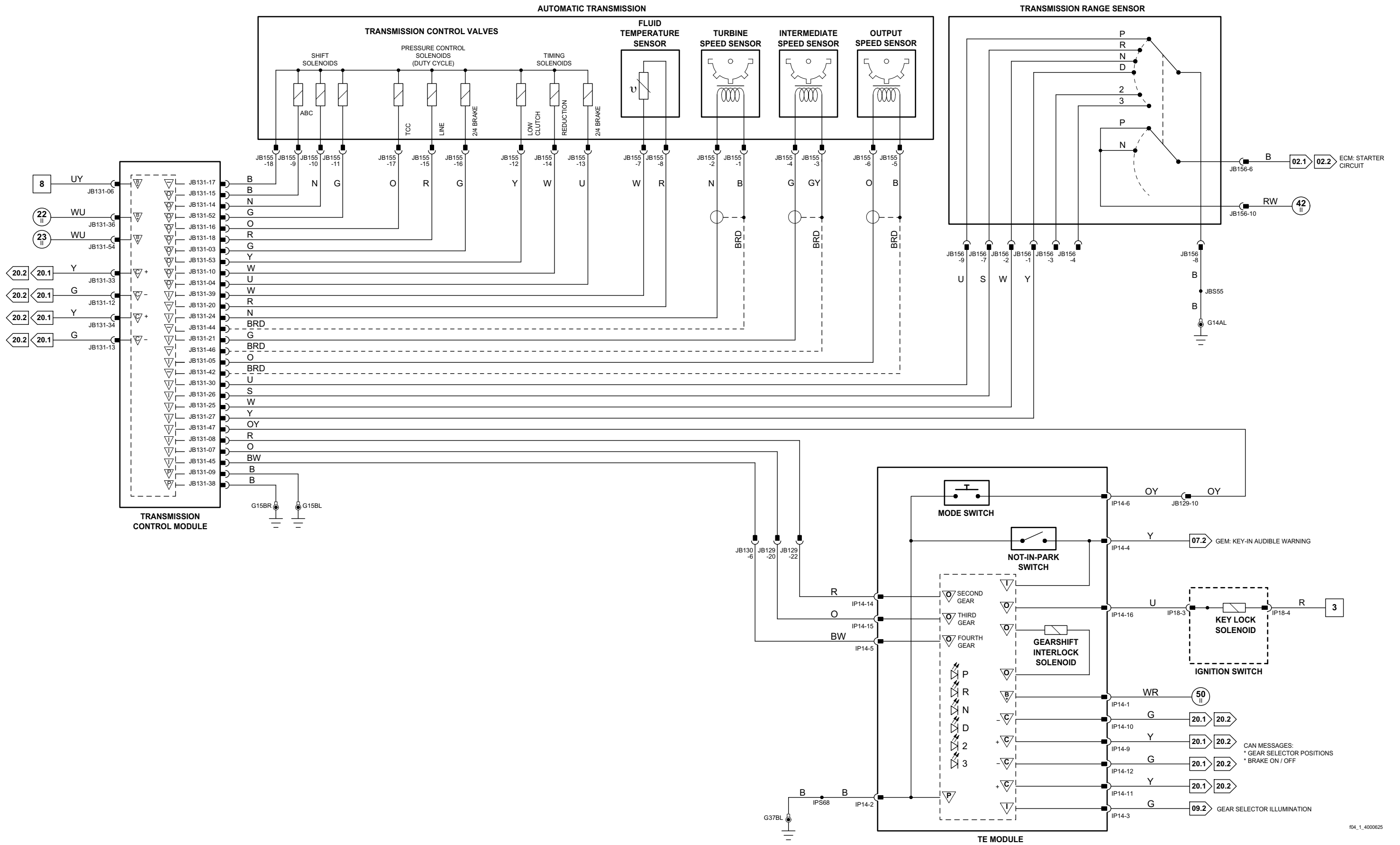

1 → 6 Fig. 01.1	34 → 79 Fig. 01.3	11 → 31 Fig. 01.5	67 → 76 Fig. 01.7	98 → 107 Fig. 01.9	Input	Battery Voltage	Sensor/Signal Supply V	CAN	D2B Network
7 → 33 Fig. 01.2	1 → 10 Fig. 01.4	32 → 66 Fig. 01.6	77 → 97 Fig. 01.8		Output	Power Ground	Sensor/Signal Ground	SCP	Serial and Encoded Data

VARIANT: 16-Bit TCM Vehicles
 VIN RANGE: Early Production Sedan Vehicles
 DATE OF ISSUE: January 2007

Transmission Control Module – 32-BIT

Pin	Description and Characteristic
O	JB230-01 LINE PRESSURE CONTROL SOLENOID DRIVE: PWM, 1.25 kHz, POSITIVE DUTY CYCLE 5 – 95%
O	JB230-02 2 / 4 BRAKE PRESSURE CONTROL SOLENOID DRIVE: PWM, 1.25 kHz, POSITIVE DUTY CYCLE 5 – 95%
O	JB230-03 TCC PRESSURE CONTROL SOLENOID DRIVE: PWM, 1.25 kHz, POSITIVE DUTY CYCLE 5 – 95%
SG	JB230-04 SOLENOID GROUND RETURN: GROUND
C	JB230-05 CAN +
C	JB230-06 CAN –
O	JB230-07 REDUCTION TIMING SOLENOID DRIVE: B+ TO ACTIVATE
O	JB230-08 LOW CLUTCH TIMING SOLENOID DRIVE: B+ TO ACTIVATE
B+	JB230-10 IGNITION SWITCHED POWER SUPPLY: B+
O	JB230-11 SHIFT SOLENOID A DRIVE: B+ TO ACTIVATE
O	JB230-12 SHIFT SOLENOID B DRIVE: B+ TO ACTIVATE
C	JB230-14 CAN +
C	JB230-15 CAN –
I	JB230-18 RANGE SENSOR – P: P = GROUND; NOT IN P = OPEN CIRCUIT
B+	JB230-19 IGNITION SWITCHED POWER SUPPLY: B+
O	JB230-20 SHIFT SOLENOID C DRIVE: B+ TO ACTIVATE
O	JB230-21 2 / 4 BRAKE TIMING SOLENOID DRIVE: B+ TO ACTIVATE
SG	JB230-23 TURBINE SPEED SENSOR GROUND: GROUND
I	JB230-24 GEAR SELECTOR SIGNAL – 3: 3 = GROUND; NOT IN 3 = OPEN CIRCUIT
PG	JB231-25 POWER GROUND: GROUND
SG	JB231-26 SENSOR GROUND: GROUND
I	JB231-27 GEAR SELECTOR SIGNAL – 2: 2 = GROUND; NOT IN 2 = OPEN CIRCUIT
B+	JB231-28 BATTERY POWER SUPPLY: B+
I	JB231-29 OUTPUT SPEED SENSOR SIGNAL: 18 PULSES PER OUTPUT SHAFT REVOLUTION
I	JB231-34 RANGE SENSOR – D: D = GROUND; NOT IN D = OPEN CIRCUIT
I	JB231-35 RANGE SENSOR – R: R = GROUND; NOT IN R = OPEN CIRCUIT
I	JB231-36 RANGE SENSOR – N: N = GROUND; NOT IN N = OPEN CIRCUIT
I	JB231-38 TURBINE SPEED SENSOR SIGNAL: 36 PULSES PER ENGINE REVOLUTION
I	JB231-39 INTERMEDIATE SPEED SENSOR SIGNAL: 54 PULSES PER INTERMEDIATE SHAFT REVOLUTION*
I	JB231-41 MODE SWITCH: 'SPORT' SELECTED = GROUND
SG	JB231-42 SENSOR GROUND: GROUND
I	JB231-43 GEAR SELECTOR SIGNAL – 4: 4 = GROUND; NOT IN 4 = OPEN CIRCUIT
SG	JB231-44 SENSOR GROUND: GROUND
I	JB231-47 FLUID TEMPERATURE SENSOR SIGNAL, NOMINAL 0 – 5 V: NTC SENSOR – VOLTAGE DECREASES AS TEMPERATURE INCREASES
PG	JB231-48 POWER GROUND: GROUND

The following abbreviations are used to represent values for Control Module Pin-Out data

I	Input	PG	Power Ground	C	CAN Network	D	Serial and Encoded Data
O	Output	SS	Sensor / Signal Supply V	S	SCP Network	V	Voltage (DC)
B+	Battery Voltage	SG	Sensor / Signal Ground	D2	D2B Network	PWM	Pulse Width Modulated

CAUTION: The information on this data page is furnished to aid the user in understanding circuit operation. THIS INFORMATION SHOULD BE USED FOR REFERENCE ONLY.

NOTE: The values listed are approximately those that can be expected at the control module connector pins with all circuit connections made and all components connected and fitted.

Fig. 04.2

COMPONENTS

Component	Connector(s)	Connector Description	Location
AUTOMATIC TRANSMISSION	JB155	18-WAY / BLACK	ENGINE COMPARTMENT
IGNITION SWITCH	IP18	7-WAY / BLACK	STEERING COLUMN
J-GATE MODULE	IP14	16-WAY / GREY	CENTER CONSOLE
TRANSMISSION CONTROL MODULE – 32-BIT	JB230	24-WAY / WHITE	LOWER LH 'A' POST
	JB231	24-WAY / GREY	
TRANSMISSION RANGE SENSOR	JB156	10-WAY / BLACK	TOP OF TRANSMISSION

HARNESS IN-LINE CONNECTORS

Connector	Connector Description / Location	Location
JB129	22-WAY / GREY / JUNCTION BOX HARNESS TO INSTRUMENT PANEL HARNESS	BELOW INSTRUMENT PANEL / LH SIDE

GROUNDS

Ground	Harness	Location
G14	JB	ENGINE COMPARTMENT / BEHIND POWER DISTRIBUTION FUSEBOX
G15	CA	LOWER LH 'A' POST
G37	IP	BEHIND INSTRUMENT PANEL / RH SIDE OF CROSS CAR BEAM

FOR CONTROL MODULE PIN-OUT INFORMATION, UNFOLD PAGE TO LEFT.

Refer to the front of this book for detailed information and illustrations regarding the location and identification of harnesses, relays, fuses, grounds, control modules and control module pins.

AUTOMATIC TRANSMISSION

TRANSMISSION RANGE SENSOR

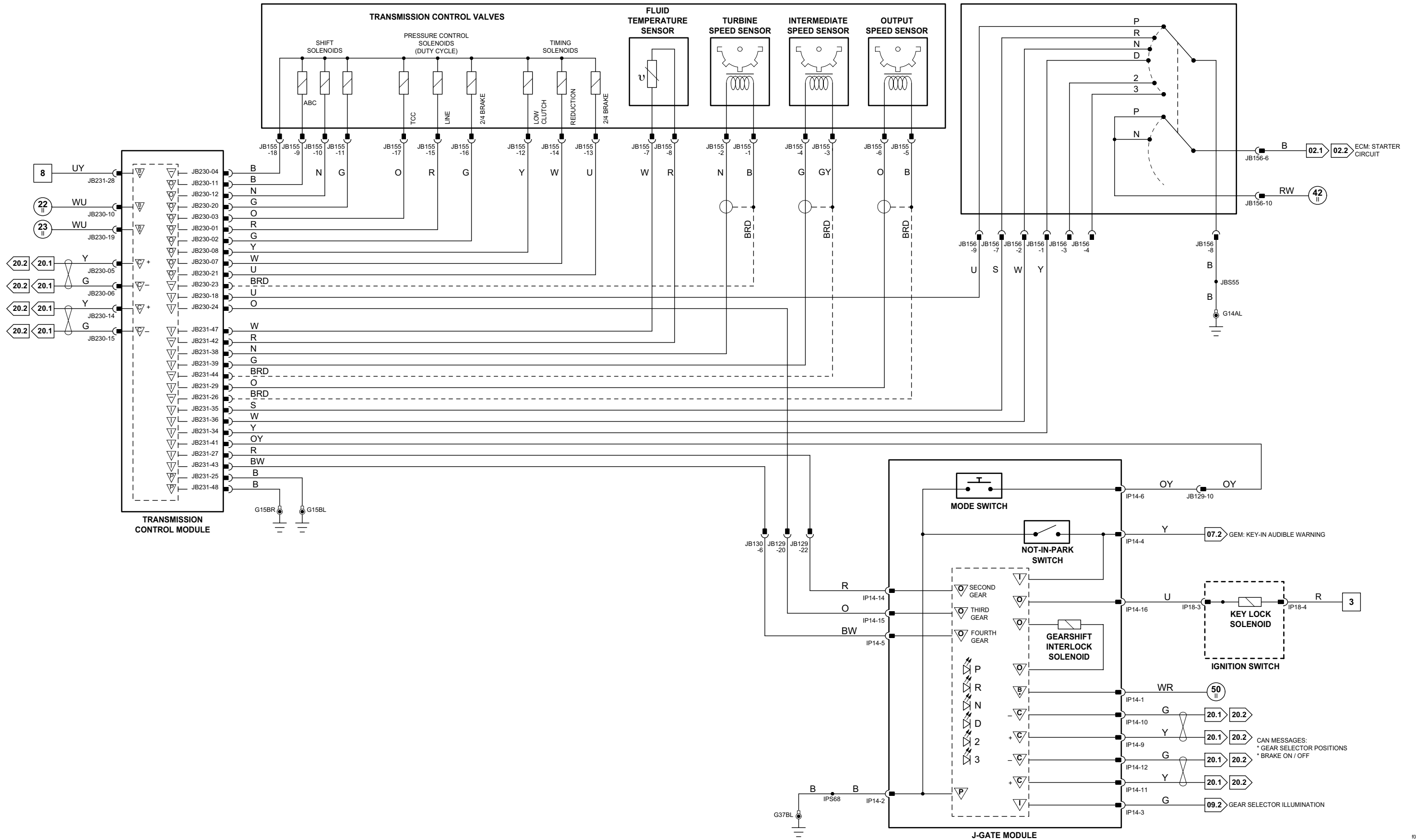

1 → 6 Fig. 01.1	34 → 79 Fig. 01.3	11 → 31 Fig. 01.5	67 → 76 Fig. 01.7	98 → 107 Fig. 01.9	Input	Battery Voltage	Sensor/Signal Supply V	CAN	D2B Network
7 → 33 Fig. 01.2	1 → 10 Fig. 01.4	32 → 66 Fig. 01.6	77 → 97 Fig. 01.8		Output	Power Ground	Sensor/Signal Ground	SCP	Serial and Encoded Data

VARIANT: 32-Bit TCM Vehicles
 VIN RANGE: All
 DATE OF ISSUE: January 2007