

## Anti-Lock Braking System Module

|    | Pin     | Description and Characteristic                                     |
|----|---------|--|
| PG | JB45-01 | MOTOR GROUND: GROUND   |
| B+ | JB45-02 | BATTERY POWER SUPPLY – MOTOR: B+                                   |
| PG | JB45-05 | POWER GROUND: GROUND   |
| B+ | JB45-06 | BATTERY POWER SUPPLY: B+   |
| I  | JB45-12 | LH FRONT WHEEL SPEED SENSOR SIGNAL: 32 PULSES PER WHEEL REVOLUTION |
| SS | JB45-13 | LH REAR WHEEL SPEED SENSOR SUPPLY VOLTAGE: B+                      |
| I  | JB45-14 | LH REAR WHEEL SPEED SENSOR SIGNAL: 32 PULSES PER WHEEL REVOLUTION  |
| SS | JB45-15 | RH FRONT WHEEL SPEED SENSOR SUPPLY VOLTAGE: B+                     |
| I  | JB45-16 | RH FRONT WHEEL SPEED SENSOR SIGNAL: 32 PULSES PER WHEEL REVOLUTION |
| B+ | JB45-23 | IGNITION SWITCHED POWER SUPPLY: B+                                 |
| C  | JB45-24 | CAN +  |
| O  | JB45-28 | LH FRONT WHEEL SPEED SENSOR SUPPLY VOLTAGE: B+                     |
| O  | JB45-30 | RH REAR WHEEL SPEED SENSOR SUPPLY VOLTAGE: B+                      |
| I  | JB45-31 | RH REAR WHEEL SPEED SENSOR SIGNAL: 32 PULSES PER WHEEL REVOLUTION  |
| I  | JB45-32 | BRAKE ON / OFF SWITCH: NORMALLY OPEN / B+ WHEN ACTIVATED           |
| C  | JB45-40 | CAN –  |

## Fig. 05.1

### COMPONENTS

| Component  | Connector(s) | Connector Description | Location                     |
|--|--------------|-----------------------|------------------------------|
| ANTI-LOCK BRAKING SYSTEM MODULE                    | JB45         | 42-WAY / BLUE         | ENGINE COMPARTMENT / RH SIDE |
| BRAKE ON / OFF SWITCH                              | PA3          | 3-WAY / BLACK         | TOP OF BRAKE PEDAL           |
| VACUUM MODULE                                      | JB240        | 5-WAY / BLACK         | UNDER BATTERY TRAY           |
|  | JB241        | 2-WAY / BLACK         |                              |
|  | JB242        | 2-WAY / GREY          |                              |
| VACUUM PUMP  | VP1          | 2-WAY / GREY          | ADJACENT TO BRAKE SERVO      |
| WHEEL SPEED SENSOR – LH FRONT                      | LF1          | 2-WAY / BLACK         | LH FRONT WHEEL HUB           |
| WHEEL SPEED SENSOR – LH REAR: 2.0 L                | LR1          | 2-WAY / BLACK         | LH REAR WHEEL HUB            |
| WHEEL SPEED SENSOR – LH REAR: 2.5 L, 3.0 L, Diesel | CA55         | 2-WAY / BLACK         | LH REAR WHEEL HUB            |
| WHEEL SPEED SENSOR – RH FRONT                      | RF1          | 2-WAY / BLACK         | RH FRONT WHEEL HUB           |
| WHEEL SPEED SENSOR – RH REAR: 2.0 L                | RR1          | 2-WAY / BLACK         | RH REAR WHEEL HUB            |
| WHEEL SPEED SENSOR – RH REAR: 2.5 L, 3.0 L, Diesel | CA60         | 2-WAY / BLACK         | RH REAR WHEEL HUB            |

### HARNESS IN-LINE CONNECTORS

| Connector | Connector Description / Location  | Location                             |
|-----------|---|--------------------------------------|
| CA10      | 22-WAY / SLATE / CABIN HARNESS TO JUNCTION BOX HARNESS                              | LH 'A' POST / 'A' POST TRIM          |
| CA170     | 16-WAY / GREEN / JUNCTION BOX HARNESS TO CABIN HARNESS                              | LH 'A' POST / 'A' POST TRIM          |
| JB2       | 16-WAY / GREEN / ENGINE MANAGEMENT HARNESS TO JUNCTION BOX HARNESS (PEDAL ASSEMBLY) | BELOW INSTRUMENT PANEL / DRIVER SIDE |
| JB15      | 2-WAY / BLACK / JUNCTION BOX HARNESS TO RH WHEEL SPEED SENSOR LINK LEAD             | BEHIND RH FRONT WHEEL ARCH LINER     |
| JB133     | 2-WAY / BLACK / JUNCTION BOX HARNESS TO LH WHEEL SPEED SENSOR LINK LEAD             | BEHIND LH FRONT WHEEL ARCH LINER     |
| JB196     | 10-WAY / GREY / ENGINE MANAGEMENT HARNESS TO JUNCTION BOX HARNESS (PEDAL ASSEMBLY)  | BELOW INSTRUMENT PANEL / DRIVER SIDE |

### GROUND

| Ground | Harness | Location   |
|--------|---------|--|
| G14    | JB      | ENGINE COMPARTMENT / BEHIND POWER DISTRIBUTION FUSEBOX |
| G18    | JB      | ENGINE COMPARTMENT / BEHIND RH HEADLAMP                |

FOR CONTROL MODULE PIN-OUT INFORMATION, UNFOLD PAGE TO LEFT.

The following abbreviations are used to represent values for Control Module Pin-Out data

|    |                 |    |                          |    |             |     |                         |
|----|-----------------|----|--------------------------|----|-------------|-----|-------------------------|
| I  | Input           | PG | Power Ground             | C  | CAN Network | D   | Serial and Encoded Data |
| O  | Output          | SS | Sensor / Signal Supply V | S  | SCP Network | V   | Voltage (DC)            |
| B+ | Battery Voltage | SG | Sensor / Signal Ground   | D2 | D2B Network | PWM | Pulse Width Modulated   |

**CAUTION:** The information on this data page is furnished to aid the user in understanding circuit operation. THIS INFORMATION SHOULD BE USED FOR REFERENCE ONLY.

**NOTE:** The values listed are approximately those that can be expected at the control module connector pins with all circuit connections made and all components connected and fitted.

Refer to the front of this book for detailed information and illustrations regarding the location and identification of harnesses, relays, fuses, grounds, control modules and control module pins.

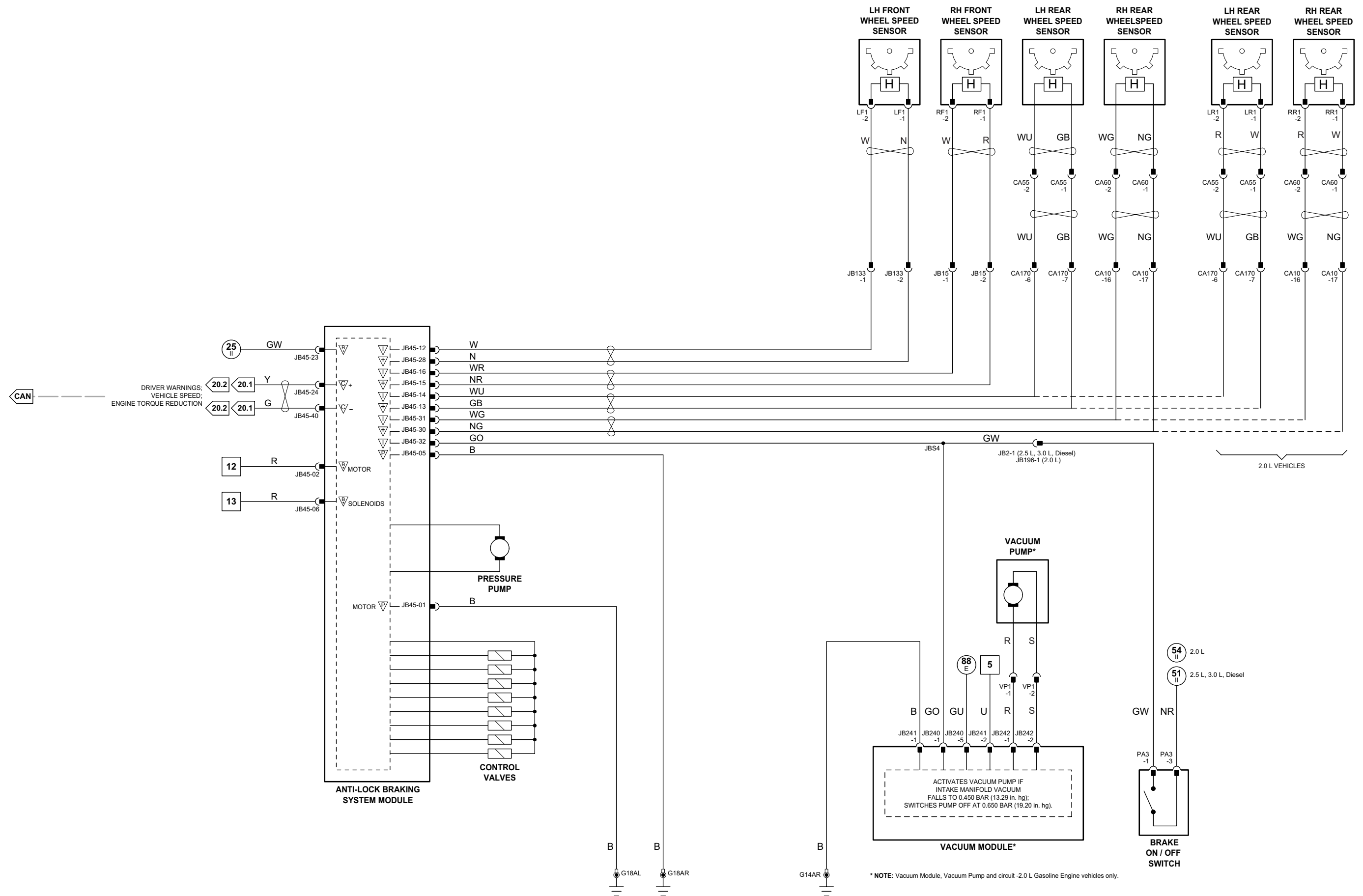

## Anti-Lock Braking / Traction Control Module

|    | Pin      | Description and Characteristic                                     |
|----|----------|--|
| PG | JB197-01 | MOTOR GROUND: GROUND   |
| B+ | JB197-02 | BATTERY POWER SUPPLY – MOTOR: B+                                   |
| PG | JB197-05 | POWER GROUND: GROUND   |
| B+ | JB197-06 | BATTERY POWER SUPPLY: B+   |
| I  | JB197-12 | LH FRONT WHEEL SPEED SENSOR SIGNAL: 32 PULSES PER WHEEL REVOLUTION |
| SS | JB197-13 | LH REAR WHEEL SPEED SENSOR SUPPLY VOLTAGE: B+                      |
| I  | JB197-14 | LH REAR WHEEL SPEED SENSOR SIGNAL: 32 PULSES PER WHEEL REVOLUTION  |
| SS | JB197-15 | RH FRONT WHEEL SPEED SENSOR SUPPLY VOLTAGE: B+                     |
| I  | JB197-16 | RH FRONT WHEEL SPEED SENSOR SIGNAL: 32 PULSES PER WHEEL REVOLUTION |
| B+ | JB197-23 | IGNITION SWITCHED POWER SUPPLY: B+                                 |
| C  | JB197-24 | CAN +  |
| I  | JB197-27 | TRACTION CONTROL SWITCH SIGNAL: GROUND WHEN ACTIVATED              |
| O  | JB197-28 | LH FRONT WHEEL SPEED SENSOR SUPPLY VOLTAGE: B+                     |
| O  | JB197-30 | RH REAR WHEEL SPEED SENSOR SUPPLY VOLTAGE: B+                      |
| I  | JB197-31 | RH REAR WHEEL SPEED SENSOR SIGNAL: 32 PULSES PER WHEEL REVOLUTION  |
| I  | JB197-32 | BRAKE ON / OFF SWITCH: NORMALLY OPEN / B+ WHEN ACTIVATED           |
| C  | JB197-40 | CAN –  |

## Fig. 05.2

### COMPONENTS

| Component  | Connector(s) | Connector Description | Location                     |
|--|--------------|-----------------------|------------------------------|
| ANTI-LOCK BRAKING / TRACTION CONTROL MODULE        | JB197        | 42-WAY / BLUE         | ENGINE COMPARTMENT / RH SIDE |
| BRAKE ON / OFF SWITCH                              | PA3          | 3-WAY / BLACK         | TOP OF BRAKE PEDAL           |
| TRACTION CONTROL SWITCH                            | IP29         | 6-WAY / BLACK         | INSTRUMENT PANEL             |
| VACUUM MODULE                                      | JB240        | 5-WAY / BLACK         | UNDER BATTERY TRAY           |
|  | JB241        | 2-WAY / BLACK         |                              |
|  | JB242        | 2-WAY / GREY          |                              |
| VACUUM PUMP  | VP1          | 2-WAY / GREY          | ADJACENT TO BRAKE SERVO      |
| WHEEL SPEED SENSOR – LH FRONT                      | LF1          | 2-WAY / BLACK         | LH FRONT WHEEL HUB           |
| WHEEL SPEED SENSOR – LH REAR: 2.0 L                | LR1          | 2-WAY / BLACK         | LH REAR WHEEL HUB            |
| WHEEL SPEED SENSOR – LH REAR: 2.5 L, 3.0 L, Diesel | CA55         | 2-WAY / BLACK         | LH REAR WHEEL HUB            |
| WHEEL SPEED SENSOR – RH FRONT                      | RF1          | 2-WAY / BLACK         | RH FRONT WHEEL HUB           |
| WHEEL SPEED SENSOR – RH REAR: 2.0 L                | RR1          | 2-WAY / BLACK         | RH REAR WHEEL HUB            |
| WHEEL SPEED SENSOR – RH REAR: 2.5 L, 3.0 L, Diesel | CA60         | 2-WAY / BLACK         | RH REAR WHEEL HUB            |

### HARNESS IN-LINE CONNECTORS

| Connector | Connector Description / Location  | Location                             |
|-----------|---|--------------------------------------|
| CA10      | 22-WAY / SLATE / CABIN HARNESS TO JUNCTION BOX HARNESS                              | LH 'A' POST / 'A' POST TRIM          |
| CA170     | 16-WAY / GREEN / JUNCTION BOX HARNESS TO CABIN HARNESS                              | LH 'A' POST / 'A' POST TRIM          |
| JB2       | 16-WAY / GREEN / ENGINE MANAGEMENT HARNESS TO JUNCTION BOX HARNESS (PEDAL ASSEMBLY) | BELOW INSTRUMENT PANEL / DRIVER SIDE |
| JB15      | 2-WAY / BLACK / JUNCTION BOX HARNESS TO RH WHEEL SPEED SENSOR LINK LEAD             | BEHIND RH FRONT WHEEL ARCH LINER     |
| JB130     | 22-WAY / GREEN / JUNCTION BOX HARNESS TO INSTRUMENT PANEL HARNESS                   | BELOW INSTRUMENT PANEL / LH SIDE     |
| JB133     | 2-WAY / BLACK / JUNCTION BOX HARNESS TO LH WHEEL SPEED SENSOR LINK LEAD             | BEHIND LH FRONT WHEEL ARCH LINER     |
| JB196     | 10-WAY / GREY / ENGINE MANAGEMENT HARNESS TO JUNCTION BOX HARNESS (PEDAL ASSEMBLY)  | BELOW INSTRUMENT PANEL / DRIVER SIDE |

### GROUNDS

| Ground | Harness | Location   |
|--------|---------|--|
| G14    | JB      | ENGINE COMPARTMENT / BEHIND POWER DISTRIBUTION FUSEBOX |
| G18    | JB      | ENGINE COMPARTMENT / BEHIND RH HEADLAMP                |
| G37    | IP      | BEHIND INSTRUMENT PANEL / RH SIDE OF CROSS CAR BEAM    |

FOR CONTROL MODULE PIN-OUT INFORMATION, UNFOLD PAGE TO LEFT.

The following abbreviations are used to represent values for Control Module Pin-Out data

|    |                 |    |                          |    |             |     |                         |
|----|-----------------|----|--------------------------|----|-------------|-----|-------------------------|
| I  | Input           | PG | Power Ground             | C  | CAN Network | D   | Serial and Encoded Data |
| O  | Output          | SS | Sensor / Signal Supply V | S  | SCP Network | V   | Voltage (DC)            |
| B+ | Battery Voltage | SG | Sensor / Signal Ground   | D2 | D2B Network | PWM | Pulse Width Modulated   |

**CAUTION:** The information on this data page is furnished to aid the user in understanding circuit operation. THIS INFORMATION SHOULD BE USED FOR REFERENCE ONLY.

**NOTE:** The values listed are approximately those that can be expected at the control module connector pins with all circuit connections made and all components connected and fitted.

Refer to the front of this book for detailed information and illustrations regarding the location and identification of harnesses, relays, fuses, grounds, control modules and control module pins.

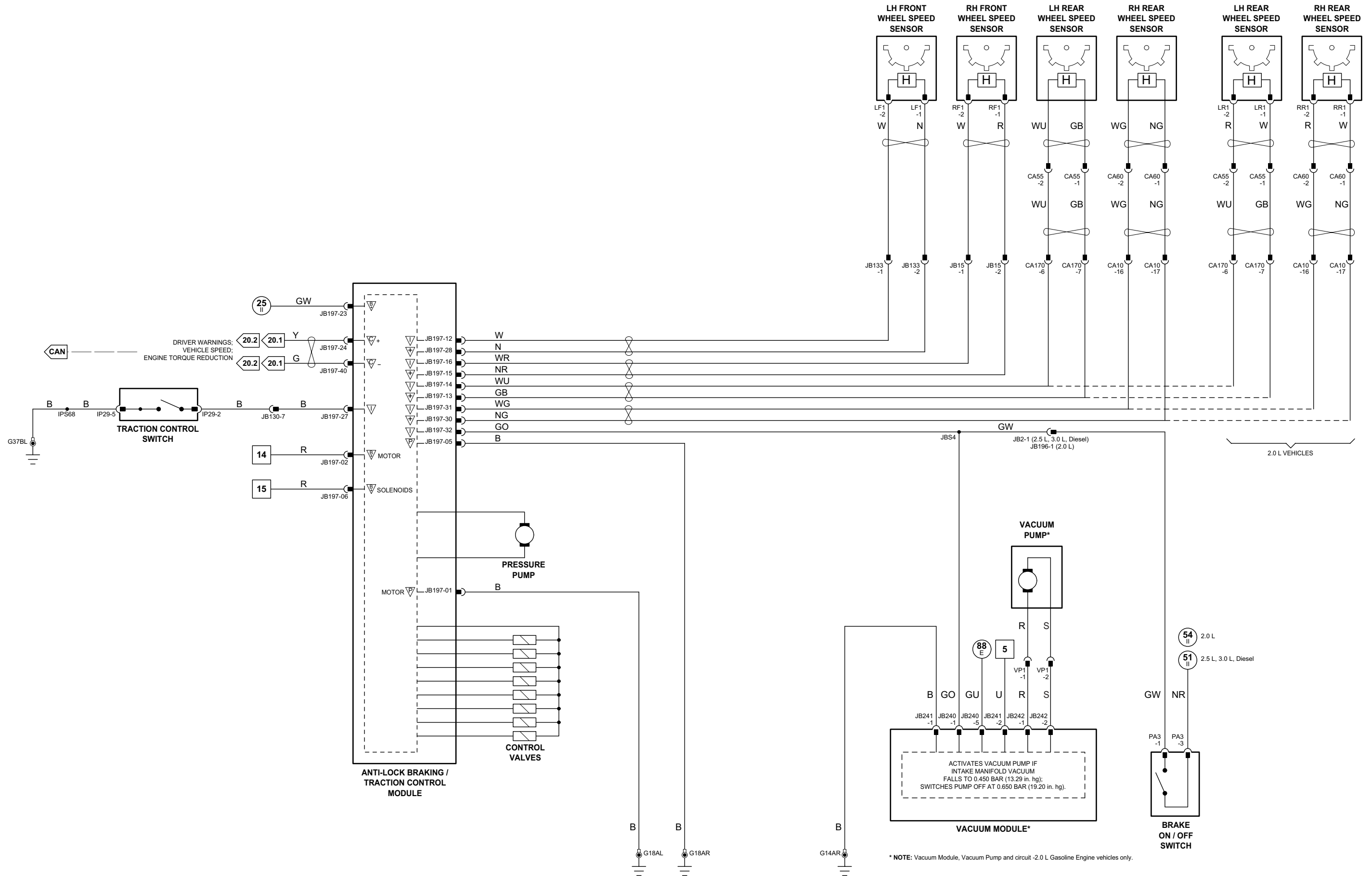

## Dynamic Stability Control Module

|    | Pin      | Description and Characteristic   |
|----|----------|--|
| PG | JB185-01 | MOTOR GROUND: GROUND   |
| B+ | JB185-02 | BATTERY POWER SUPPLY – MOTOR: B+   |
| PG | JB185-05 | POWER GROUND: GROUND   |
| B+ | JB185-06 | BATTERY POWER SUPPLY: B+   |
| I  | JB185-12 | LH FRONT WHEEL SPEED SENSOR SIGNAL: 32 PULSES PER WHEEL REVOLUTION                     |
| SS | JB185-13 | LH REAR WHEEL SPEED SENSOR SUPPLY VOLTAGE: B+  |
| I  | JB185-14 | LH REAR WHEEL SPEED SENSOR SIGNAL: 32 PULSES PER WHEEL REVOLUTION                      |
| SS | JB185-15 | RH FRONT WHEEL SPEED SENSOR SUPPLY VOLTAGE: B+   |
| I  | JB185-16 | RH FRONT WHEEL SPEED SENSOR SIGNAL: 32 PULSES PER WHEEL REVOLUTION                     |
| SG | JB185-21 | SENSOR GROUND – YAW RATE, STEERING ANGLE SENSORS: GROUND                               |
| B+ | JB185-23 | IGNITION SWITCHED POWER SUPPLY: B+   |
| C  | JB185-24 | CAN +  |
| SG | JB185-25 | SENSOR GROUND – BRAKE PRESSURE SENSOR: GROUND  |
| I  | JB185-26 | BRAKE PRESSURE SENSOR SIGNAL, NOMINAL 0 – 5 V: VOLTAGE INCREASES AS PRESSURE INCREASES |
| I  | JB185-27 | DYNAMIC STABILITY CONTROL SWITCH: NORMALLY OPEN / GROUND WHEN ACTIVATED                |
| O  | JB185-28 | LH FRONT WHEEL SPEED SENSOR SUPPLY VOLTAGE: B+   |
| O  | JB185-30 | RH REAR WHEEL SPEED SENSOR SUPPLY VOLTAGE: B+  |
| I  | JB185-31 | RH REAR WHEEL SPEED SENSOR SIGNAL: 32 PULSES PER WHEEL REVOLUTION                      |
| I  | JB185-32 | BRAKE ON / OFF SWITCH: NORMALLY OPEN / B+ WHEN ACTIVATED                               |
| SS | JB185-39 | YAW RATE, STEERING ANGLE SENSORS SUPPLY VOLTAGE: B+                                    |
| C  | JB185-40 | CAN –  |
| SS | JB185-42 | BRAKE PRESSURE SENSOR SUPPLY VOLTAGE: NOMINAL 5 V                                      |

## Fig. 05.3

### COMPONENTS

| Component  | Connector(s) | Connector Description | Location                               |
|--|--------------|-----------------------|--|
| BRAKE ON / OFF SWITCH                              | PA3          | 3-WAY / BLACK         | TOP OF BRAKE PEDAL                     |
| BRAKE PRESSURE SENSOR                              | JB89         | 3-WAY / BLACK         | ON DYNAMIC STABILITY CONTROL MODULATOR |
| DYNAMIC STABILITY CONTROL MODULE                   | JB185        | 42-WAY / BLUE         | ENGINE COMPARTMENT / RH SIDE           |
| DYNAMIC STABILITY CONTROL SWITCH                   | IP29         | 6-WAY / BLACK         | INSTRUMENT PANEL                       |
| STEERING ANGLE SENSOR                              | IP19         | 4-WAY / BLACK         | STEERING COLUMN                        |
| VACUUM MODULE                                      | JB240        | 5-WAY / BLACK         | UNDER BATTERY TRAY                     |
|  | JB241        | 2-WAY / BLACK         |  |
|  | JB242        | 2-WAY / GREY          |  |
| VACUUM PUMP  | VP1          | 2-WAY / GREY          | ADJACENT TO BRAKE SERVO                |
| WHEEL SPEED SENSOR – LH FRONT                      | LF1          | 2-WAY / BLACK         | LH FRONT WHEEL HUB                     |
| WHEEL SPEED SENSOR – LH REAR: 2.0 L                | LR1          | 2-WAY / BLACK         | LH REAR WHEEL HUB                      |
| WHEEL SPEED SENSOR – LH REAR: 2.5 L, 3.0 L, Diesel | CA55         | 2-WAY / BLACK         | LH REAR WHEEL HUB                      |
| WHEEL SPEED SENSOR – RH FRONT                      | RF1          | 2-WAY / BLACK         | RH FRONT WHEEL HUB                     |
| WHEEL SPEED SENSOR – RH REAR: 2.0 L                | RR1          | 2-WAY / BLACK         | RH REAR WHEEL HUB                      |
| WHEEL SPEED SENSOR – RH REAR: 2.5 L, 3.0 L, Diesel | CA60         | 2-WAY / BLACK         | RH REAR WHEEL HUB                      |
| YAW RATE SENSOR                                    | IP20         | 4-WAY / BLACK         | BEHIND CENTER CONSOLE                  |

### HARNESS IN-LINE CONNECTORS

| Connector | Connector Description / Location  | Location                             |
|-----------|---|--------------------------------------|
| CA10      | 22-WAY / SLATE / CABIN HARNESS TO JUNCTION BOX HARNESS                              | LH 'A' POST / 'A' POST TRIM          |
| CA170     | 16-WAY / GREEN / JUNCTION BOX HARNESS TO CABIN HARNESS                              | LH 'A' POST / 'A' POST TRIM          |
| JB2       | 16-WAY / GREEN / ENGINE MANAGEMENT HARNESS TO JUNCTION BOX HARNESS (PEDAL ASSEMBLY) | BELOW INSTRUMENT PANEL / DRIVER SIDE |
| JB15      | 2-WAY / BLACK / JUNCTION BOX HARNESS TO RH WHEEL SPEED SENSOR LINK LEAD             | BEHIND RH FRONT WHEEL ARCH LINER     |
| JB129     | 22-WAY / GREY / JUNCTION BOX HARNESS TO INSTRUMENT PANEL HARNESS                    | BELOW INSTRUMENT PANEL / LH SIDE     |
| JB130     | 22-WAY / GREEN / JUNCTION BOX HARNESS TO INSTRUMENT PANEL HARNESS                   | BELOW INSTRUMENT PANEL / LH SIDE     |
| JB133     | 2-WAY / BLACK / JUNCTION BOX HARNESS TO LH WHEEL SPEED SENSOR LINK LEAD             | BEHIND LH FRONT WHEEL ARCH LINER     |
| JB196     | 10-WAY / GREY / ENGINE MANAGEMENT HARNESS TO JUNCTION BOX HARNESS (PEDAL ASSEMBLY)  | BELOW INSTRUMENT PANEL / DRIVER SIDE |

### GROUNDS

| Ground | Harness | Location   |
|--------|---------|--|
| G14    | JB      | ENGINE COMPARTMENT / BEHIND POWER DISTRIBUTION FUSEBOX |
| G18    | JB      | ENGINE COMPARTMENT / BEHIND RH HEADLAMP                |
| G37    | IP      | BEHIND INSTRUMENT PANEL / RH SIDE OF CROSS CAR BEAM    |

FOR CONTROL MODULE PIN-OUT INFORMATION, UNFOLD PAGE TO LEFT.

The following abbreviations are used to represent values for Control Module Pin-Out data

|    |                 |    |                          |    |             |     |                         |
|----|-----------------|----|--------------------------|----|-------------|-----|-------------------------|
| I  | Input           | PG | Power Ground             | C  | CAN Network | D   | Serial and Encoded Data |
| O  | Output          | SS | Sensor / Signal Supply V | S  | SCP Network | V   | Voltage (DC)            |
| B+ | Battery Voltage | SG | Sensor / Signal Ground   | D2 | D2B Network | PWM | Pulse Width Modulated   |

**CAUTION:** The information on this data page is furnished to aid the user in understanding circuit operation. THIS INFORMATION SHOULD BE USED FOR REFERENCE ONLY.

**NOTE:** The values listed are approximately those that can be expected at the control module connector pins with all circuit connections made and all components connected and fitted.

Refer to the front of this book for detailed information and illustrations regarding the location and identification of harnesses, relays, fuses, grounds, control modules and control module pins.

