

**Climate Control Module – Manual**

Pin	Description and Characteristic
O	AC1-04 FRESH / RECIRCULATION FLAP ACTUATOR DRIVE: TO ACTIVATE, A/CCM SWITCHES CIRCUIT TO B+ OR TO GROUND
O	AC1-05 FRESH / RECIRCULATION FLAP ACTUATOR DRIVE: TO ACTIVATE, A/CCM SWITCHES CIRCUIT TO B+ OR TO GROUND
O	AC1-06 DEFROST DOOR ACTUATOR STEPPER COIL 1 DRIVE: TO ACTIVATE, A/CCM SWITCHES CIRCUIT TO GROUND
O	AC1-07 DEFROST DOOR ACTUATOR STEPPER COIL 2 DRIVE: TO ACTIVATE, A/CCM SWITCHES CIRCUIT TO GROUND
O	AC1-08 PANEL / FLOOR ACTUATOR STEPPER COIL 1 DRIVE: TO ACTIVATE, A/CCM SWITCHES CIRCUIT TO GROUND
O	AC1-09 PANEL / FLOOR ACTUATOR STEPPER COIL 2 DRIVE: TO ACTIVATE, A/CCM SWITCHES CIRCUIT TO GROUND
O	AC1-10 AIR TEMPERATURE BLEND ACTUATOR STEPPER COIL 1 DRIVE: TO ACTIVATE, A/CCM SWITCHES CIRCUIT TO GROUND
O	AC1-11 AIR TEMPERATURE BLEND ACTUATOR STEPPER COIL 2 DRIVE: TO ACTIVATE, A/CCM SWITCHES CIRCUIT TO GROUND
O	AC1-12 AIR TEMPERATURE BLEND ACTUATOR POWER SUPPLY: B+
O	AC1-13 DEFROST DOOR ACTUATOR POWER SUPPLY: B+
I	AC1-14 EVAPORATOR TEMPERATURE SENSOR SIGNAL, NOMINAL 0 – 5 V: NTC SENSOR – VOLTAGE DECREASES AS TEMPERATURE INCREASES
I	AC1-15 DISCHARGE TEMPERATURE SENSOR SIGNAL, NOMINAL 0 – 5 V: NTC SENSOR – VOLTAGE DECREASES AS TEMPERATURE INCREASES
SG	AC1-16 SENSOR GROUND: GROUND
O	AC1-20 DEFROST DOOR ACTUATOR STEPPER COIL 3 DRIVE: TO ACTIVATE, A/CCM SWITCHES CIRCUIT TO GROUND
O	AC1-21 DEFROST DOOR ACTUATOR STEPPER COIL 4 DRIVE: TO ACTIVATE, A/CCM SWITCHES CIRCUIT TO GROUND
O	AC1-22 PANEL / FLOOR ACTUATOR STEPPER COIL 3 DRIVE: TO ACTIVATE, A/CCM SWITCHES CIRCUIT TO GROUND
O	AC1-23 PANEL / FLOOR ACTUATOR STEPPER COIL 4 DRIVE: TO ACTIVATE, A/CCM SWITCHES CIRCUIT TO GROUND
O	AC1-24 AIR TEMPERATURE BLEND ACTUATOR STEPPER COIL 3 DRIVE: TO ACTIVATE, A/CCM SWITCHES CIRCUIT TO GROUND
O	AC1-25 AIR TEMPERATURE BLEND ACTUATOR STEPPER COIL 4 DRIVE: TO ACTIVATE, A/CCM SWITCHES CIRCUIT TO GROUND
O	AC1-26 PANEL / FLOOR ACTUATOR POWER SUPPLY: B+
O	IP39-01 BLOWER SPEED CONTROL 6: TO ACTIVATE, A/CCM SWITCHES CIRCUIT TO GROUND
O	IP39-02 BLOWER SPEED CONTROL 4: TO ACTIVATE, A/CCM SWITCHES CIRCUIT TO GROUND
O	IP39-03 BLOWER SPEED CONTROL 2: TO ACTIVATE, A/CCM SWITCHES CIRCUIT TO GROUND
O	IP39-04 BLOWER SPEED CONTROL 3: TO ACTIVATE, A/CCM SWITCHES CIRCUIT TO GROUND
O	IP39-06 BLOWER SPEED CONTROL 5: TO ACTIVATE, A/CCM SWITCHES CIRCUIT TO GROUND
B+	IP101-01 BATTERY SAVER POWER SUPPLY: B+
B+	IP101-02 IGNITION SWITCHED POWER SUPPLY: B+
I	IP101-07 BLOWER SPEED SENSE: B+ WHEN BLOWER OFF, 0 V WHEN BLOWER RUNNING
C	IP101-09 CAN +
C	IP101-10 CAN –
B+	IP101-14 BATTERY POWER SUPPLY: B+
PG	IP101-15 POWER GROUND: GROUND
I	IP101-20 DIMMER CONTROLLED ILLUMINATION: PWM, 80 Hz, GROUND = 0% DUTY CYCLE, B+ = 100% DUTY CYCLE
C	IP101-22 CAN +
C	IP101-23 CAN –
O	IP135-01 BLOWER SPEED CONTROL 1: TO ACTIVATE, A/CCM SWITCHES CIRCUIT TO GROUND
PG	IP135-02 BLOWER GROUND: GROUND

**Fig. 06.1**

**COMPONENTS**

Component	Connector(s)	Connector Description	Location
AIR CONDITIONING BLOWER RELAY	–	–	PASSENGER JUNCTION FUSEBOX – R4
AIR TEMPERATURE BLEND ACTUATOR	AC2	6-WAY / BLACK	RH SIDE OF AIR DISTRIBUTION UNIT
BLOWER – MANUAL CLIMATE CONTROL	IP58	2-WAY / GREY	LHD: BEHIND INSTRUMENT PANEL / RH SIDE RHD: BEHIND INSTRUMENT PANEL / LH SIDE
BLOWER SERIES RESISTOR	IP121	6-WAY / GREY	ADJACENT TO BLOWER MOTOR
CLIMATE CONTROL MODULE – PANEL	AC1	26-WAY / YELLOW	BEHIND CLIMATE CONTROL PANEL
	IP39	4-WAY / GREY	
	IP101	26-WAY / WHITE	
	IP135	2-WAY / GREY	
DEFROST DOOR ACTUATOR	AC4	6-WAY / BLACK	RH SIDE OF AIR DISTRIBUTION UNIT
DISCHARGE TEMPERATURE SENSOR	AC6	2-WAY / BLACK	RH SIDE OF AIR DISTRIBUTION UNIT
EVAPORATOR TEMPERATURE SENSOR	AC5	2-WAY / BLACK	RH SIDE OF AIR DISTRIBUTION UNIT
FRESH / RECIRCULATION FLAP ACTUATOR	AC7	4-WAY / BLACK	LHD: LH SIDE OF AIR DISTRIBUTION UNIT RHD: RH SIDE OF AIR DISTRIBUTION UNIT
PANEL / FLOOR ACTUATOR	AC3	6-WAY / BLACK	RH SIDE OF AIR DISTRIBUTION UNIT
PASSENGER JUNCTION FUSEBOX	–	–	PASSENGER COMPARTMENT, FRONT BULKHEAD / LH SIDE

**GROUNDS**

Ground	Harness	Location
G15	CA	LOWER LH 'A' POST
G36	IP	BEHIND INSTRUMENT PANEL / LH SIDE OF CROSS CAR BEAM
G37	IP	BEHIND INSTRUMENT PANEL / RH SIDE OF CROSS CAR BEAM

**FOR CONTROL MODULE PIN-OUT INFORMATION, UNFOLD PAGE TO LEFT.**

The following abbreviations are used to represent values for Control Module Pin-Out data

I	Input	PG	Power Ground	C	CAN Network	D	Serial and Encoded Data
O	Output	SS	Sensor / Signal Supply V	S	SCP Network	V	Voltage (DC)
B+	Battery Voltage	SG	Sensor / Signal Ground	D2	D2B Network	PWM	Pulse Width Modulated

**CAUTION:** The information on this data page is furnished to aid the user in understanding circuit operation. THIS INFORMATION SHOULD BE USED FOR REFERENCE ONLY.

**NOTE:** The values listed are approximately those that can be expected at the control module connector pins with all circuit connections made and all components connected and fitted.

Refer to the front of this book for detailed information and illustrations regarding the location and identification of harnesses, relays, fuses, grounds, control modules and control module pins.

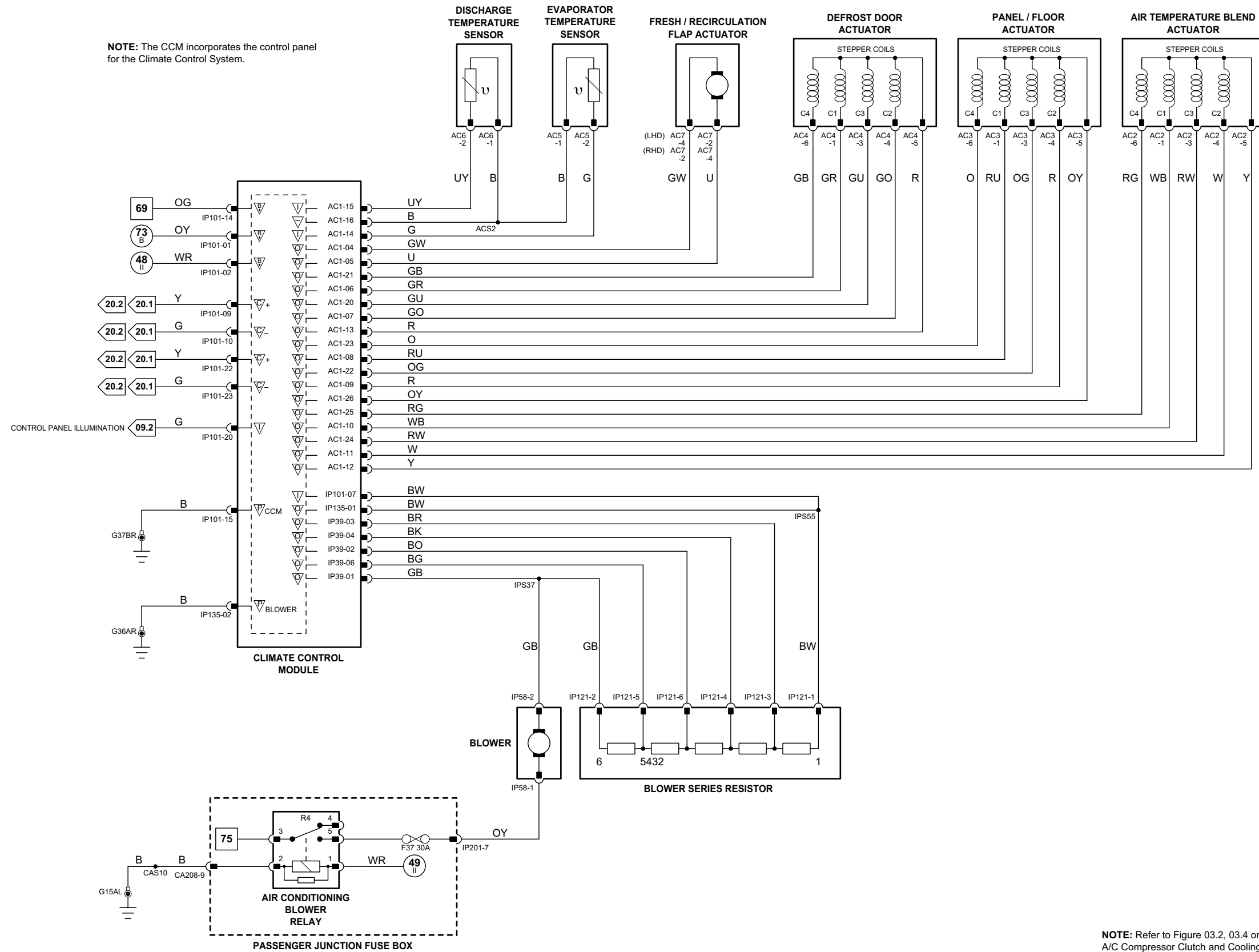

**NOTE:** Refer to Figure 03.2, 03.4 or 03.6 for A/C Compressor Clutch and Cooling Fan circuits.

106\_1\_4000625

**Climate Control Module – Automatic**

Pin	Description and Characteristic
O	AC1-04 FRESH / RECIRCULATION FLAP ACTUATOR DRIVE: TO ACTIVATE, A/CCM SWITCHES CIRCUIT TO B+ OR TO GROUND
O	AC1-05 FRESH / RECIRCULATION FLAP ACTUATOR DRIVE: TO ACTIVATE, A/CCM SWITCHES CIRCUIT TO B+ OR TO GROUND
O	AC1-06 DEFROST DOOR ACTUATOR STEPPER COIL 1 DRIVE: TO ACTIVATE, A/CCM SWITCHES CIRCUIT TO GROUND
O	AC1-07 DEFROST DOOR ACTUATOR STEPPER COIL 2 DRIVE: TO ACTIVATE, A/CCM SWITCHES CIRCUIT TO GROUND
O	AC1-08 PANEL / FLOOR ACTUATOR STEPPER COIL 1 DRIVE: TO ACTIVATE, A/CCM SWITCHES CIRCUIT TO GROUND
O	AC1-09 PANEL / FLOOR ACTUATOR STEPPER COIL 2 DRIVE: TO ACTIVATE, A/CCM SWITCHES CIRCUIT TO GROUND
O	AC1-10 AIR TEMPERATURE BLEND ACTUATOR STEPPER COIL 1 DRIVE: TO ACTIVATE, A/CCM SWITCHES CIRCUIT TO GROUND
O	AC1-11 AIR TEMPERATURE BLEND ACTUATOR STEPPER COIL 2 DRIVE: TO ACTIVATE, A/CCM SWITCHES CIRCUIT TO GROUND
O	AC1-12 AIR TEMPERATURE BLEND ACTUATOR POWER SUPPLY: B+
O	AC1-13 DEFROST DOOR ACTUATOR POWER SUPPLY: B+
I	AC1-14 EVAPORATOR TEMPERATURE SENSOR SIGNAL, NOMINAL 0 – 5 V: NTC SENSOR – VOLTAGE DECREASES AS TEMPERATURE INCREASES
I	AC1-15 DISCHARGE TEMPERATURE SENSOR SIGNAL, NOMINAL 0 – 5 V: NTC SENSOR – VOLTAGE DECREASES AS TEMPERATURE INCREASES
I	AC1-16 SENSOR GROUND: GROUND
O	AC1-20 DEFROST DOOR ACTUATOR STEPPER COIL 3 DRIVE: TO ACTIVATE, A/CCM SWITCHES CIRCUIT TO GROUND
O	AC1-21 DEFROST DOOR ACTUATOR STEPPER COIL 4 DRIVE: TO ACTIVATE, A/CCM SWITCHES CIRCUIT TO GROUND
O	AC1-22 PANEL / FLOOR ACTUATOR STEPPER COIL 3 DRIVE: TO ACTIVATE, A/CCM SWITCHES CIRCUIT TO GROUND
O	AC1-23 PANEL / FLOOR ACTUATOR STEPPER COIL 4 DRIVE: TO ACTIVATE, A/CCM SWITCHES CIRCUIT TO GROUND
O	AC1-24 AIR TEMPERATURE BLEND ACTUATOR STEPPER COIL 3 DRIVE: TO ACTIVATE, A/CCM SWITCHES CIRCUIT TO GROUND
O	AC1-25 AIR TEMPERATURE BLEND ACTUATOR STEPPER COIL 4 DRIVE: TO ACTIVATE, A/CCM SWITCHES CIRCUIT TO GROUND
O	AC1-26 PANEL / FLOOR ACTUATOR POWER SUPPLY: B+
B+	IP101-01 BATTERY SAVER POWER SUPPLY: B+
B+	IP101-02 IGNITION SWITCHED POWER SUPPLY: B+
I	IP101-05 ASPIRATOR MOTOR DRIVE: PERMANENTLY CONNECTED TO GROUND; A/CCM MONITORS CIRCUIT FOR MOTOR RUNNING CONDITION
O	IP101-06 BLOWER MOTOR CONTROL: PWM, 400 Hz, APPROXIMATELY 8% – 90%; HIGHER DUTY CYCLE = HIGHER BLOWER SPEED
I	IP101-07 BLOWER MOTOR SPEED SENSE: FREQUENCY = RPM / 20; FREQUENCY PROPORTIONAL TO BLOWER SPEED
C	IP101-09 CAN +
C	IP101-10 CAN –
B+	IP101-14 BATTERY POWER SUPPLY: B+
PG	IP101-15 POWER GROUND: GROUND
I	IP101-16 IN-CAR TEMPERATURE SENSOR SIGNAL, NOMINAL 0 – 5 V: NTC SENSOR – VOLTAGE DECREASES AS TEMPERATURE INCREASES
SG	IP101-17 SENSOR GROUND: GROUND
I	IP101-19 AMBIENT TEMPERATURE SENSOR SIGNAL, NOMINAL 0 – 5 V: NTC SENSOR – VOLTAGE DECREASES AS TEMPERATURE INCREASES
I	IP101-20 DIMMER CONTROLLED ILLUMINATION: PWM, 80 Hz, GROUND = 0% DUTY CYCLE, B+ = 100% DUTY CYCLE
O	IP101-21 AIR CONDITIONING BLOWER RELAY DRIVE: TO ACTIVATE, A/CCM SWITCHES CIRCUIT TO B+
C	IP101-22 CAN +
C	IP101-23 CAN –

The following abbreviations are used to represent values for Control Module Pin-Out data

I	Input	PG	Power Ground	C	CAN Network	D	Serial and Encoded Data
O	Output	SS	Sensor / Signal Supply V	S	SCP Network	V	Voltage (DC)
B+	Battery Voltage	SG	Sensor / Signal Ground	D2	D2B Network	PWM	Pulse Width Modulated

**CAUTION:** The information on this data page is furnished to aid the user in understanding circuit operation. THIS INFORMATION SHOULD BE USED FOR REFERENCE ONLY.

**NOTE:** The values listed are approximately those that can be expected at the control module connector pins with all circuit connections made and all components connected and fitted.

**Fig. 06.2**

**COMPONENTS**

Component	Connector(s)	Connector Description	Location
AIR CONDITIONING BLOWER RELAY	–	–	PASSENGER JUNCTION FUSEBOX – R4
AIR TEMPERATURE BLEND ACTUATOR	AC2	6-WAY / BLACK	RH SIDE OF AIR DISTRIBUTION UNIT
AMBIENT TEMPERATURE SENSOR	JB105	2-WAY / BLACK	FRONT CROSS MEMBER, ADJACENT TO RADIATOR / LH SIDE
BLOWER – AUTOMATIC CLIMATE CONTROL	IP134	6-WAY / BLACK	BEHIND INSTRUMENT PANEL / RH SIDE
CLIMATE CONTROL MODULE – REMOTE	AC1	26-WAY / YELLOW	RH SIDE OF AIR DISTRIBUTION UNIT
	IP101	26-WAY / WHITE	
DEFROST DOOR ACTUATOR	AC4	6-WAY / BLACK	RH SIDE OF AIR DISTRIBUTION UNIT
DISCHARGE TEMPERATURE SENSOR	AC6	2-WAY / BLACK	RH SIDE OF AIR DISTRIBUTION UNIT
EVAPORATOR TEMPERATURE SENSOR	AC5	2-WAY / BLACK	RH SIDE OF AIR DISTRIBUTION UNIT
FRESH / RECIRCULATION FLAP ACTUATOR	AC7	4-WAY / BLACK	LHD: LH SIDE OF AIR DISTRIBUTION UNIT RHD: RH SIDE OF AIR DISTRIBUTION UNIT
IN-CAR TEMPERATURE SENSOR	IP66	4-WAY / BLACK	BELOW INSTRUMENT PANEL CENTER RIGHT
PANEL / FLOOR ACTUATOR	AC3	6-WAY / BLACK	RH SIDE OF AIR DISTRIBUTION UNIT
PASSENGER JUNCTION FUSEBOX	–	–	PASSENGER COMPARTMENT, FRONT BULKHEAD / LH SIDE

**HARNES IN-LINE CONNECTORS**

Connector	Connector Description / Location	Location
JB3	14-WAY / BLUE / JUNCTION BOX HARNESS TO INSTRUMENT PANEL HARNESS	BELOW INSTRUMENT PANEL / LH SIDE

**GROUNDS**

Ground	Harness	Location
G15	CA	LOWER LH 'A' POST
G36	IP	BEHIND INSTRUMENT PANEL / LH SIDE OF CROSS CAR BEAM
G37	IP	BEHIND INSTRUMENT PANEL / RH SIDE OF CROSS CAR BEAM

**NOTE:** FOR CONTROL MODULE PIN-OUT INFORMATION, UNFOLD PAGE TO LEFT.

Refer to the front of this book for detailed information and illustrations regarding the location and identification of harnesses, relays, fuses, grounds, control modules and control module pins.

**NOTE:** Vehicles without Navigation 'Touch Screen' - The CCM incorporates the control panel for the Climate Control System.

Vehicles with Navigation 'Touch Screen' - The CCM is remotely mounted on the Climate Control Unit. Driver control inputs are received via Network Communication.

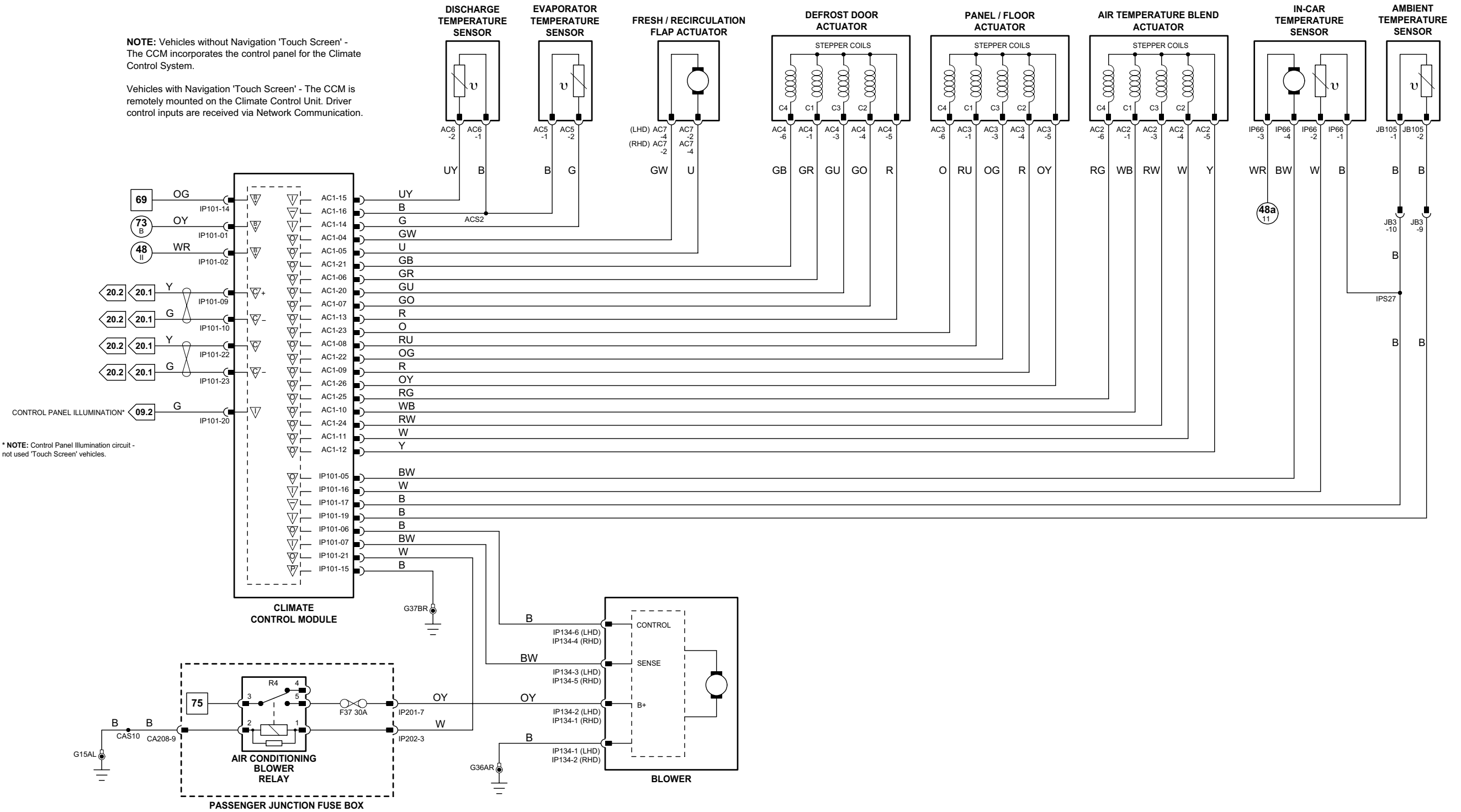

**NOTE:** Refer to Figure 03.2, 03.4 or 03.6 for A/C Compressor Clutch and Cooling Fan circuits.

**Climate Control Module – Manual or Automatic**

	Pin	Description and Characteristic
O	IP101-03	WINDSHIELD HEATER RELAY DRIVE: TO ACTIVATE, A/CCM SWITCHES CIRCUIT TO GROUND
O	IP101-04	HEATED REAR WINDOW RELAY DRIVE: TO ACTIVATE, A/CCM SWITCHES CIRCUIT TO GROUND

**Driver Seat Module**

	Pin	Description and Characteristic
I	DM1-10	HEATED REAR WINDOW RELAY ACTIVATED SIGNAL
O	DM1-14	DOOR MIRROR MOVEMENT / HEATERS DRIVE
B+	DM2-01	BATTERY POWER SUPPLY: B+
SG	DM2-03	SIGNAL GROUND: GROUND
B+	DM2-04	IGNITION SWITCHED POWER SUPPLY II: B+
PG	DM2-05	POWER GROUND: GROUND
B+	DM2-06	BATTERY POWER SUPPLY: B+

**Fig. 06.3**

**COMPONENTS**

Component	Connector(s)	Connector Description	Location
CLIMATE CONTROL MODULE – PANEL	AC1	26-WAY / YELLOW	BEHIND CLIMATE CONTROL PANEL
	IP39	4-WAY / GREY	
	IP101	26-WAY / WHITE	
	IP135	2-WAY / GREY	
	AC1	26-WAY / YELLOW	RH SIDE OF AIR DISTRIBUTION UNIT
CLIMATE CONTROL MODULE – REMOTE	IP101	26-WAY / WHITE	
	AC1	26-WAY / YELLOW	RH SIDE OF AIR DISTRIBUTION UNIT
	IP101	26-WAY / WHITE	
	DD5	22-WAY / GREY	DRIVER DOOR
	PD4	22-WAY / GREY	PASSENGER DOOR
DOOR MIRROR – DRIVER	DD5	22-WAY / GREY	DRIVER DOOR
	PD4	22-WAY / GREY	PASSENGER DOOR
	DD5	22-WAY / GREY	DRIVER DOOR
	PD4	22-WAY / GREY	PASSENGER DOOR
	WG5	2-WAY / BLACK	REAR WINDOW
HEATED REAR WINDOW – ESTATE (WAGON)	WG5	2-WAY / BLACK	REAR WINDOW
	ZA1	1-WAY / BLACK	REAR WINDOW
HEATED REAR WINDOW – SEDAN	ZA1	1-WAY / BLACK	REAR WINDOW
	ZA10	1-WAY / BLACK	
HEATED REAR WINDOW RELAY	-	-	PASSENGER JUNCTION FUSEBOX – R6
PASSENGER JUNCTION FUSEBOX	-	-	PASSENGER COMPARTMENT, FRONT BULKHEAD / LH SIDE
POWER DISTRIBUTION FUSEBOX	-	-	ENGINE COMPARTMENT
SEAT MODULE – DRIVER	DM2	10-WAY / GREY	DRIVER SEAT SWITCH PACK
	DM3	16-WAY / BLACK	
	DM4	8-WAY / BLUE	
	DM5	8-WAY / GREEN	
	JB95	2-WAY / BLACK	WINDSHIELD / LH SIDE
WINDSHIELD HEATER – LH	JB95	2-WAY / BLACK	WINDSHIELD / LH SIDE
WINDSHIELD HEATER – RH	JB96	2-WAY / BLACK	WINDSHIELD / RH SIDE
WINDSHIELD HEATER RELAY	-	-	POWER DISTRIBUTION FUSEBOX – R6

**HARNES IN-LINE CONNECTORS**

Connector	Connector Description / Location	Location
CA15	20-WAY / BLACK / CABIN HARNESS TO DRIVER DOOR HARNESS	DRIVER DOOR / DOOR CASING
CA16	20-WAY / BLACK / CABIN HARNESS TO DRIVER DOOR HARNESS	DRIVER DOOR / DOOR CASING
CA20	20-WAY / BLACK / CABIN HARNESS TO PASSENGER DOOR HARNESS	PASSENGER DOOR / DOOR CASING
CA21	20-WAY / BLACK / CABIN HARNESS TO PASSENGER DOOR HARNESS	PASSENGER DOOR / DOOR CASING
CA127	2-WAY / BLACK / CABIN HARNESS TO HEATER REAR WINDOW HARNESS	BEHIND LH 'E' POST TRIM
CA431	16-WAY / GREY / CABIN HARNESS TO DRIVER SEAT HARNESS	UNDER DRIVER SEAT
JB130	22-WAY / GREEN / JUNCTION BOX HARNESS TO INSTRUMENT PANEL HARNESS	BELOW INSTRUMENT PANEL / LH SIDE
WG3	3-WAY / BLACK / CABIN HARNESS TO TAIL GATE GLASS HARNESS	ROOF / CENTER REAR

**GROUNDS**

Ground	Harness	Location
G3	C03	LH 'E' POST
G4	CA	LOWER RH 'A' POST
G14	JB	ENGINE COMPARTMENT / BEHIND POWER DISTRIBUTION FUSEBOX
G15	CA	LOWER LH 'A' POST
G50	CA	HEADLINER / RH REAR ROOF PANEL

**FOR CONTROL MODULE PIN-OUT INFORMATION, UNFOLD PAGE TO LEFT.**

The following abbreviations are used to represent values for Control Module Pin-Out data

I	Input	PG	Power Ground	C	CAN Network	D	Serial and Encoded Data
O	Output	SS	Sensor / Signal Supply V	S	SCP Network	V	Voltage (DC)
B+	Battery Voltage	SG	Sensor / Signal Ground	D2	D2B Network	PWM	Pulse Width Modulated

**CAUTION:** The information on this data page is furnished to aid the user in understanding circuit operation. THIS INFORMATION SHOULD BE USED FOR REFERENCE ONLY.

**NOTE:** The values listed are approximately those that can be expected at the control module connector pins with all circuit connections made and all components connected and fitted.

Refer to the front of this book for detailed information and illustrations regarding the location and identification of harnesses, relays, fuses, grounds, control modules and control module pins.

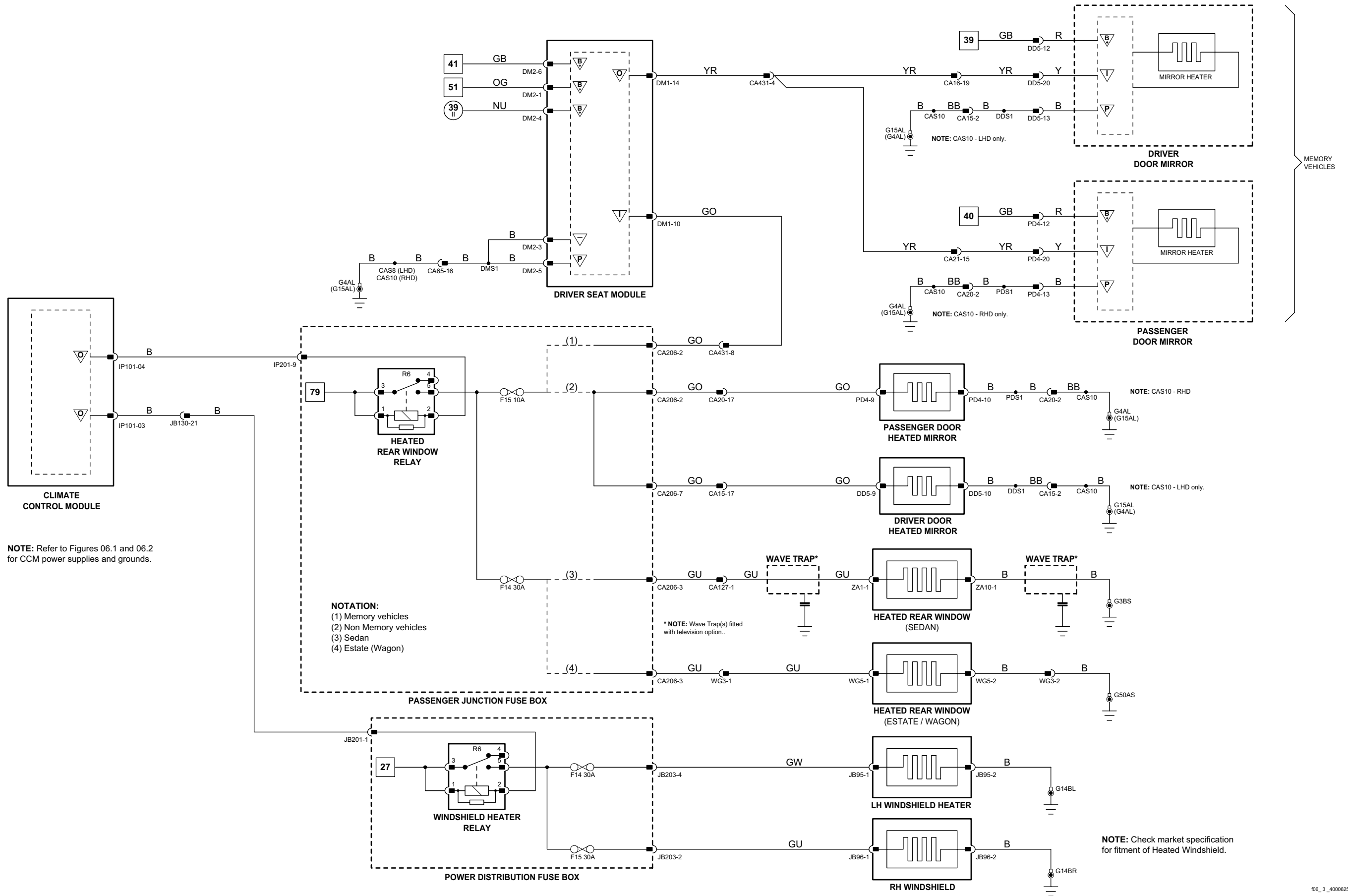

NOTE: Refer to Figures 06.1 and 06.2 for CCM power supplies and grounds.

MEMORY VEHICLES

1 → 6 Fig. 01.1	34 → 79 Fig. 01.3	11 → 31 Fig. 01.5	67 → 76 Fig. 01.7	98 → 107 Fig. 01.9	Input	Battery Voltage	Sensor/Signal Supply V	CAN	D2B Network
7 → 33 Fig. 01.2	1 → 10 Fig. 01.4	32 → 66 Fig. 01.6	77 → 97 Fig. 01.8		Output	Power Ground	Sensor/Signal Ground	SCP	Serial and Encoded Data

VARIANT: All Vehicles  
 VIN RANGE: All  
 DATE OF ISSUE: January 2007