

## General Electronic Module

	Pin	Description and Characteristic
PG	CA86-05	POWER GROUND
I	IP5-04	INTERMITTENT WIPE INTERVAL: 1 = 0.5†- 4 k; 2 = 4†- 14 k; 3 = 14†- 24 k; 4 = 24†- 34 k; 5 = 34†- 43 k; 6 = 43†- 57 k
S	IP5-18	
S	IP5-19	
O	IP5-21	
SG	IP6-01	LOGIC GROUND: GROUND
I	IP6-04	INTERMITTENT WIPE: B+ WHEN SELECTED
I	IP6-05	FRONT WASHER SWITCH: WASHER ON = GROUND; WASHER OFF = B+
B+	JB172-01	BATTERY POWER SUPPLY (LOCKING): B+
I	JB172-02	WIPER MOTOR PARK SWITCH: PARKED = GROUND; NOT PARKED = B+
B+	JB172-05	BATTERY POWER SUPPLY (TURN SIGNALS): B+
O	JB172-23	POWER WASH PUMP RELAY DRIVE: TO ACTIVATE, GEM SWITCHES CIRCUIT TO GROUND

## Fig. 13.1

### COMPONENTS

Component	Connector(s)	Connector Description	Location
GENERAL ELECTRONIC MODULE	CA86	23-WAY / GREY	BEHIND INSTRUMENT PANEL / RH SIDE
	CA87	23-WAY / GREEN	
	IP5	23-WAY / BROWN	
	IP6	23-WAY / NATURAL	
	JB172	23-WAY / BLUE	
PASSENGER JUNCTION FUSEBOX	-	-	PASSENGER COMPARTMENT, FRONT BULKHEAD / LH SIDE
POWER DISTRIBUTION FUSEBOX	-	-	ENGINE COMPARTMENT
POWERWASH PUMP	JB65	2-WAY / GREY	BEHIND RH FRONT WHEEL ARCH LINER
POWERWASH PUMP RELAY	-	-	POWER DISTRIBUTION FUSEBOX - R8
WINDSHIELD WASHER PUMP	JB109		ENGINE COMPARTMENT / RH FRONT
WINDSHIELD WIPER MOTOR RELAY	-	-	POWER DISTRIBUTION FUSEBOX - R4
WIPER MOTOR - FRONT	JB63		BASE OF WINDSHIELD / LH SIDE
WIPER SWITCH ASSEMBLY	IP16	10-WAY / GREY	STEERING COLUMN

### HARNESS IN-LINE CONNECTORS

Connector	Connector Description / Location	Location
JB3	14-WAY / BLUE / JUNCTION BOX HARNESS TO INSTRUMENT PANEL HARNESS	BELOW INSTRUMENT PANEL / LH SIDE
JB129	22-WAY / GREY / JUNCTION BOX HARNESS TO INSTRUMENT PANEL HARNESS	BELOW INSTRUMENT PANEL / LH SIDE
JB130	22-WAY / GREEN / JUNCTION BOX HARNESS TO INSTRUMENT PANEL HARNESS	BELOW INSTRUMENT PANEL / LH SIDE

### GROUNDS

Ground	Harness	Location
G4	CA	LOWER RH 'A' POST
G5	IP	UPPER RH 'A' POST
G10	JB	ENGINE COMPARTMENT / BEHIND RH HEADLAMP
G14	JB	ENGINE COMPARTMENT / BEHIND POWER DISTRIBUTION FUSEBOX
G36	IP	BEHIND INSTRUMENT PANEL / LH SIDE OF CROSS CAR BEAM
G37	IP	BEHIND INSTRUMENT PANEL / RH SIDE OF CROSS CAR BEAM

FOR CONTROL MODULE PIN-OUT INFORMATION, UNFOLD PAGE TO LEFT.

The following abbreviations are used to represent values for Control Module Pin-Out data

I	Input	PG	Power Ground	C	CAN Network	D	Serial and Encoded Data
O	Output	SS	Sensor / Signal Supply V	S	SCP Network	V	Voltage (DC)
B+	Battery Voltage	SG	Sensor / Signal Ground	D2	D2B Network	PWM	Pulse Width Modulated

CAUTION: The information on this data page is furnished to aid the user in understanding circuit operation. THIS INFORMATION SHOULD BE USED FOR REFERENCE ONLY.

NOTE: The values listed are approximately those that can be expected at the control module connector pins with all circuit connections made and all components connected and fitted.

Refer to the front of this book for detailed information and illustrations regarding the location and identification of harnesses, relays, fuses, grounds, control modules and control module pins.

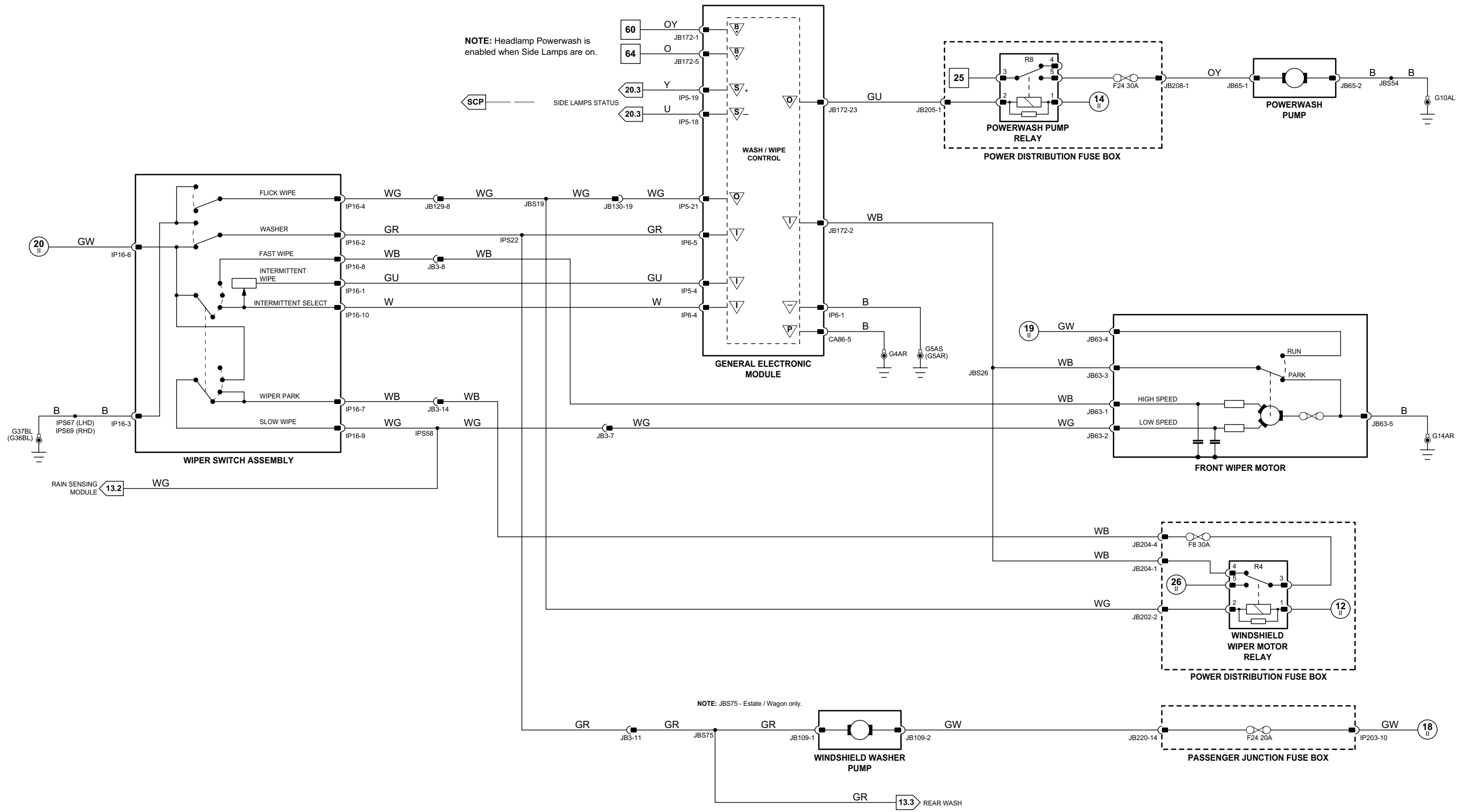

1 → 6 Fig. 01.1	34 → 79 Fig. 01.3	11 → 31 Fig. 01.5	67 → 76 Fig. 01.7	98 → 107 Fig. 01.9	Input	Battery Voltage	Sensor/Signal Supply V	CAN	D2B Network
7 → 33 Fig. 01.2	1 → 10 Fig. 01.4	32 → 66 Fig. 01.6	77 → 97 Fig. 01.8		Output	Power Ground	Sensor/Signal Ground	SCP	Serial and Encoded Data

**VARIANT:** Non Rain Sensing Vehicles  
**VIN RANGE:** All  
**DATE OF ISSUE:** January 2007

f13\_1\_4000625

**General Electronic Module**

	Pin	Description and Characteristic
PG	CA86-05	POWER GROUND
I	IP5-04	INTERMITTENT WIPE INTERVAL: 1 = 0.5†- 4 k; 2 = 4†- 14 k; 3 = 14†- 24 k; 4 = 24†- 34 k; 5 = 34†- 43 k; 6 = 43†- 57 k
S	IP5-18	
S	IP5-19	
O	IP5-21	
		WINDSHIELD WIPER RELAY DRIVE: TO ACTIVATE, CIRCUIT SWITCHED TO GROUND
SG	IP6-01	LOGIC GROUND: GROUND
I	IP6-04	INTERMITTENT WIPE: B+ WHEN SELECTED
I	IP6-05	FRONT WASHER SWITCH: WASHER ON = GROUND; WASHER OFF = B+
B+	JB172-01	BATTERY POWER SUPPLY (LOCKING): B+
I	JB172-02	WIPER MOTOR PARK SWITCH: PARKED = GROUND; NOT PARKED = B+
B+	JB172-05	BATTERY POWER SUPPLY (TURN SIGNALS): B+
O	JB172-23	POWER WASH PUMP RELAY DRIVE: TO ACTIVATE, GEM SWITCHES CIRCUIT TO GROUND

**Fig. 13.2**

**COMPONENTS**

Component	Connector(s)	Connector Description	Location
GENERAL ELECTRONIC MODULE	CA86	23-WAY / GREY	BEHIND INSTRUMENT PANEL / RH SIDE
	CA87	23-WAY / GREEN	
	IP5	23-WAY / BROWN	
	IP6	23-WAY / NATURAL	
	JB172	23-WAY / BLUE	
PASSENGER JUNCTION FUSEBOX	-	-	PASSENGER COMPARTMENT, FRONT BULKHEAD / LH SIDE
POWER DISTRIBUTION FUSEBOX	-	-	ENGINE COMPARTMENT
POWERWASH PUMP	JB65	2-WAY / GREY	BEHIND RH FRONT WHEEL ARCH LINER
POWERWASH PUMP RELAY	-	-	POWER DISTRIBUTION FUSEBOX - R8
RAIN SENSING MODULE	CA6	12-WAY / BLACK	BEHIND INSTRUMENT PANEL / LH SIDE
RAIN SENSOR	RC15	3-WAY / BLACK	BEHIND REAR VIEW MIRROR
WINDSHIELD WASHER PUMP	JB109	-	ENGINE COMPARTMENT / RH FRONT
WINDSHIELD WIPER MOTOR RELAY	-	-	POWER DISTRIBUTION FUSEBOX - R4
WIPER MOTOR - FRONT	JB63	-	BASE OF WINDSHIELD / LH SIDE
WIPER SWITCH ASSEMBLY	IP16	10-WAY / GREY	STEERING COLUMN

**HARNESS IN-LINE CONNECTORS**

Connector	Connector Description / Location	Location
CA1	22-WAY / NATURAL / INSTRUMENT PANEL HARNESS TO CABIN HARNESS	LH 'A' POST / 'A' POST TRIM
CA10	22-WAY / SLATE / CABIN HARNESS TO JUNCTION BOX HARNESS	LH 'A' POST / 'A' POST TRIM
CA40	16-WAY / GREY / CABIN HARNESS TO ROOF HARNESS	RH 'A' POST / WINDSHIELD PILLAR
CA230	16-WAY / BLUE / CABIN HARNESS TO INSTRUMENT PANEL HARNESS	LH LOWER 'A' POST / 'A' POST TRIM
JB3	14-WAY / BLUE / JUNCTION BOX HARNESS TO INSTRUMENT PANEL HARNESS	BELOW INSTRUMENT PANEL / LH SIDE
JB129	22-WAY / GREY / JUNCTION BOX HARNESS TO INSTRUMENT PANEL HARNESS	BELOW INSTRUMENT PANEL / LH SIDE
JB130	22-WAY / GREEN / JUNCTION BOX HARNESS TO INSTRUMENT PANEL HARNESS	BELOW INSTRUMENT PANEL / LH SIDE

**GROUNDS**

Ground	Harness	Location
G4	CA	LOWER RH 'A' POST
G5	IP	UPPER RH 'A' POST
G10	JB	ENGINE COMPARTMENT / BEHIND RH HEADLAMP
G14	JB	ENGINE COMPARTMENT / BEHIND POWER DISTRIBUTION FUSEBOX
G15	CA	LOWER LH 'A' POST
G36	IP	BEHIND INSTRUMENT PANEL / LH SIDE OF CROSS CAR BEAM
G37	IP	BEHIND INSTRUMENT PANEL / RH SIDE OF CROSS CAR BEAM

**FOR CONTROL MODULE PIN-OUT INFORMATION, UNFOLD PAGE TO LEFT.**

The following abbreviations are used to represent values for Control Module Pin-Out data

I	Input	PG	Power Ground	C	CAN Network	D	Serial and Encoded Data
O	Output	SS	Sensor / Signal Supply V	S	SCP Network	V	Voltage (DC)
B+	Battery Voltage	SG	Sensor / Signal Ground	D2	D2B Network	PWM	Pulse Width Modulated

**CAUTION:** The information on this data page is furnished to aid the user in understanding circuit operation. THIS INFORMATION SHOULD BE USED FOR REFERENCE ONLY.

**NOTE:** The values listed are approximately those that can be expected at the control module connector pins with all circuit connections made and all components connected and fitted.

Refer to the front of this book for detailed information and illustrations regarding the location and identification of harnesses, relays, fuses, grounds, control modules and control module pins.

NOTE: Headlamp Powerwash enabled when Side Lamps on.

SCP SIDE LAMPS STATUS

WASH / WIPE CONTROL

GENERAL ELECTRONIC MODULE

POWERWASH PUMP RELAY  
POWER DISTRIBUTION FUSE BOX

POWERWASH PUMP

FRONT WIPER MOTOR

WINDSHIELD WIPER MOTOR RELAY  
POWER DISTRIBUTION FUSE BOX

WINDSHIELD WASHER PUMP

PASSENGER JUNCTION FUSE BOX

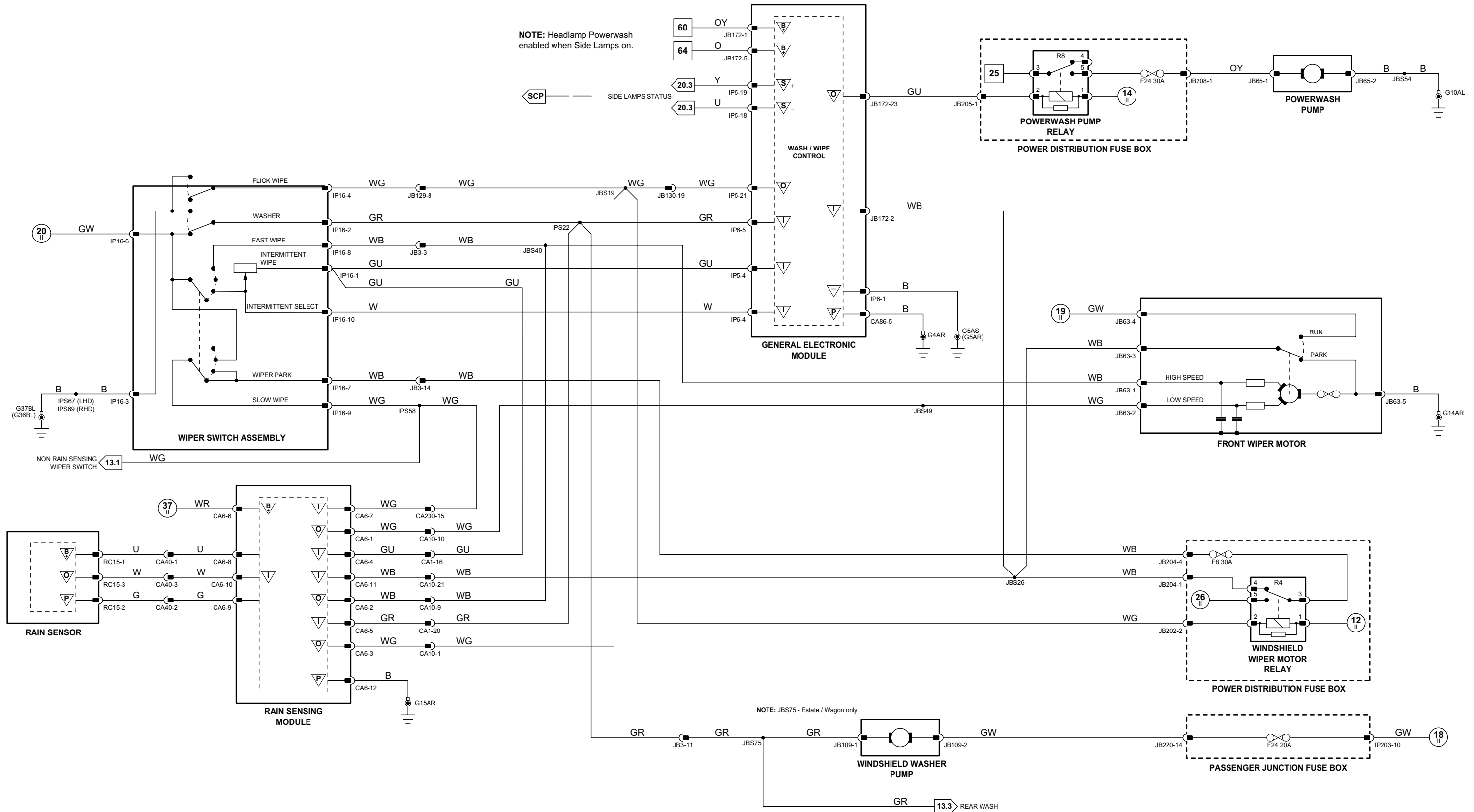

NOTE: JBS75 - Estate / Wagon only

1 → 6 Fig. 01.1	34 → 79 Fig. 01.3	11 → 31 Fig. 01.5	67 → 76 Fig. 01.7	98 → 107 Fig. 01.9
7 → 33 Fig. 01.2	1 → 10 Fig. 01.4	32 → 66 Fig. 01.6	77 → 97 Fig. 01.8	

Input	Battery Voltage	Sensor/Signal Supply V	CAN	D2B Network
Output	Power Ground	Sensor/Signal Ground	SCP	Serial and Encoded Data

VARIANT: Rain Sensing Vehicles  
VIN RANGE: All  
DATE OF ISSUE: January 2007

**General Electronic Module**

	Pin	Description and Characteristic
PG	CA86-05	POWER GROUND
I	IP5-02	REAR WASHER SWITCH: WASHER ON = GROUND; WASHER OFF = B+
I	IP5-03	ESTATE (WAGON); REAR WIPER SWITCH: B+ WHEN SELECTED
O	IP5-17	REAR WIPER MOTOR RELAY DRIVE: TO ACTIVATE, GEM SWITCH CIRCUIT TO GROUND
S	IP5-18	SCP -
S	IP5-19	SCP +
SG	IP6-01	LOGIC GROUND: GROUND
I	IP6-05	FRONT WASHER SWITCH: WASHER ON = GROUND; WASHER OFF = B+
I	IP6-12	REAR WIPER MOTOR PARK SWITCH: PARKED = GROUND; NOT PARKED = B+
B+	JB172-01	BATTERY POWER SUPPLY (LOCKING): B+
B+	JB172-05	BATTERY POWER SUPPLY (TURN SIGNALS): B+

**Fig. 13.3**

**COMPONENTS**

Component	Connector(s)	Connector Description	Location
GENERAL ELECTRONIC MODULE	CA86	23-WAY / GREY	BEHIND INSTRUMENT PANEL / RH SIDE
	CA87	23-WAY / GREEN	
	IP5	23-WAY / BROWN	
	IP6	23-WAY / NATURAL	
	JB172	23-WAY / BLUE	
	-	-	
PASSENGER JUNCTION FUSEBOX	-	-	PASSENGER COMPARTMENT, FRONT BULKHEAD / LH SIDE
WINDSHIELD WASHER PUMP	JB109		ENGINE COMPARTMENT / RH FRONT
WIPER MOTOR - REAR	WT5		TAIL GATE
WIPER MOTOR RELAY - REAR	-	-	PASSENGER JUNCTION FUSEBOX - R3
WIPER SWITCH ASSEMBLY	IP16	10-WAY / GREY	STEERING COLUMN

**HARNESS IN-LINE CONNECTORS**

Connector	Connector Description / Location	Location
CA1	22-WAY / NATURAL / INSTRUMENT PANEL HARNESS TO CABIN HARNESS	LH 'A' POST / 'A' POST TRIM
CA169	4-WAY / GREY / CABIN HARNESS TO INSTRUMENT PANEL HARNESS	LH LOWER A POST / A POST TRIM
WL3	3-WAY / BLACK / CABIN HARNESS TO TAIL GATE LINK LEAD	ROOF / CENTER REAR
WT3	3-WAY / BLACK / CABIN HARNESS TO TAIL GATE HARNESS	TAIL GATE

**GROUNDS**

Ground	Harness	Location
G1	CA	TRUNK / UNDER LH TAIL LAMP UNIT
G4	CA	LOWER RH 'A' POST
G5	IP	UPPER RH 'A' POST
G36	IP	BEHIND INSTRUMENT PANEL / LH SIDE OF CROSS CAR BEAM
G37	IP	BEHIND INSTRUMENT PANEL / RH SIDE OF CROSS CAR BEAM

FOR CONTROL MODULE PIN-OUT INFORMATION, UNFOLD PAGE TO LEFT.

The following abbreviations are used to represent values for Control Module Pin-Out data

I	Input	PG	Power Ground	C	CAN Network	D	Serial and Encoded Data
O	Output	SS	Sensor / Signal Supply V	S	SCP Network	V	Voltage (DC)
B+	Battery Voltage	SG	Sensor / Signal Ground	D2	D2B Network	PWM	Pulse Width Modulated

**CAUTION:** The information on this data page is furnished to aid the user in understanding circuit operation. THIS INFORMATION SHOULD BE USED FOR REFERENCE ONLY.

**NOTE:** The values listed are approximately those that can be expected at the control module connector pins with all circuit connections made and all components connected and fitted.

Refer to the front of this book for detailed information and illustrations regarding the location and identification of harnesses, relays, fuses, grounds, control modules and control module pins.

